

YAMAHA

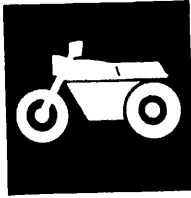

**PARTS
CATALOGUE**

XJ900F'92 (4BB2) EUROPE

248B-300E2

YAMAHA
GENUINE
Parts & Accessories

A2

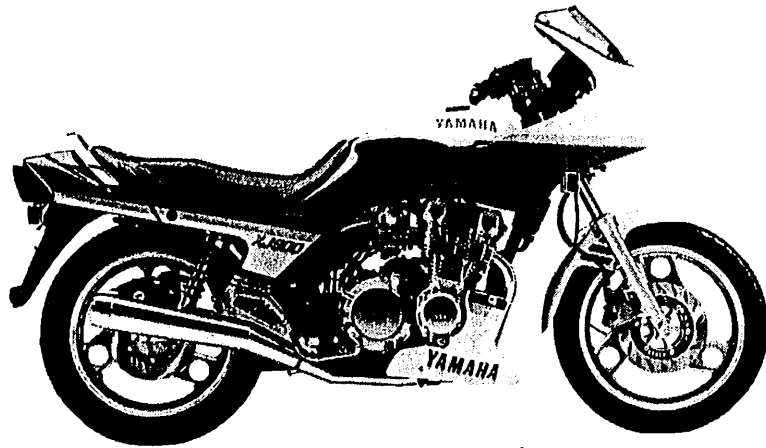

SILKY WHITE (SW)

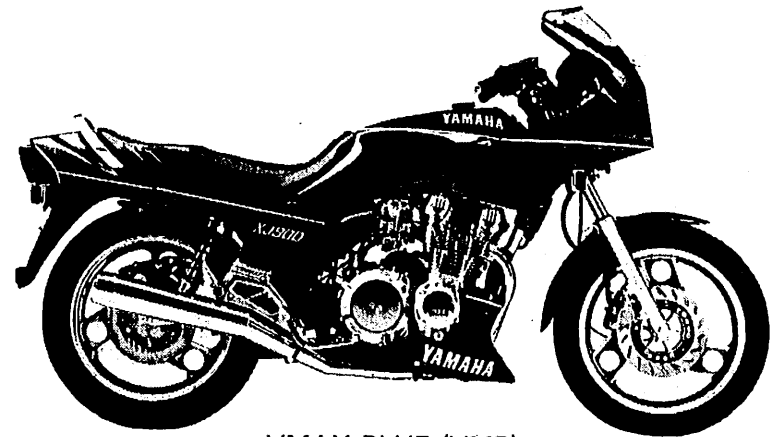

VMAX BLUE (VMB)

This Parts Catalogue is related to the parts in use for the Yamaha XJ900F'92 (4BB2). When you are ordering replacement parts for the XJ900F'92 (4BB2), refer to this Parts Catalogue and quote both part numbers and part names correctly.

1. Modifications or additions which have been made after issue of the Parts Catalogue will be announced in the Yamaha Parts News. It is advisable that according to the Yamaha Parts News you make necessary corrections to the Parts Catalogue on hand to keep it up-to-date.

2. Abbreviations

The following abbreviations are used in this Parts Catalogue.

- U.R. Use size (thickness) and/or number as required.
- U.N. Use as many as you need.
- A.P. Alternate Parts
- L.M. Local Made
- F# Frame No. (Applicable machine No.)

3. The parts marked with (*) in the parts number column of this Catalogue are not supplied with by Yamaha, those have to be found locally.
4. Parts, which are to be supplied in the form of assemblies, are listed with an indentation of one letter's space, and a dot (.) is put against the name of each part.

EXAMPLE CARBURETOR ASS'Y
 .JET, pilot
 .NOZZLE, main

5. Indication of No. of constituent parts for assembly

The numeral appearing to the right of each constituent part under the description indicates the quantity of such parts for each individual assembly unit.

EXAMPLE

Part No.	Description	Q'ty	Remarks
2F5-83310-60	FRONT FLASHER LIGHT ASS'Y	2	
115-83311-60	.BULB (6V-18W)	1	
1M1-83309-60	.REFLECTOR	1	

6. Initial Serial No. and Color Code

A Frame Serial No.	4BB-00810 and following
B Engine Serial No.	4BB-00810 and following

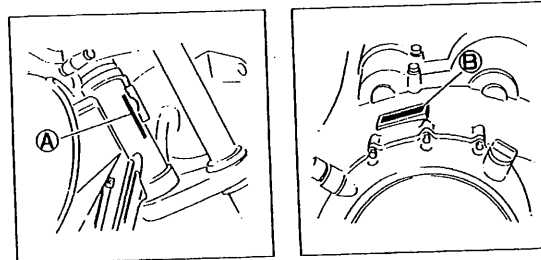

Color Code	Color Name	Abbreviate
00AU	VMAX BLUE	VMB
00GE	SILKY WHITE	SW

7. Applicable colors of graphics are represented in the "Remarks" column by the letter(s) appropriately picked out of the full word(s) showing such colors.

EXAMPLE

Part No.	Description	Q'ty	Remarks
2N4-24110-00-X5	FUEL TANK COMP.	1	MAXIM RED
3J1-24240-10	.GRAPHIC, fuel tank set	1	for MXR

8. This Parts Catalogue contains modified specs as opposed to the preceding one. The modified items are asterisked (*) before their respective Ref. Nos. For the convenience of reference. Table of Comparison between old and new is provided at the end of this catalogue.

CONTENTS

ENGINE

Cylinder Head	B2
Cylinder	B3
Crankshaft · Piston	B4
Valve	B5 ~ B6
Camshaft · Chain	B7
Oil Pump	B8
Oil Cooler	B9
Oil Cleaner	B10
Intake	B11
Carburetor	B12 ~ B13
Exhaust	B14
Crankcase	B15 ~ C2
Crankcase Cover 1	C3 ~ C4
Starter	C5
Clutch	C6 ~ C7
Transmission	C8 ~ C9
Middle Drive Gear	C10 ~ C11
Shift Cam · Fork	C12
Shift Shaft	C13

CHASSIS

Frame	C14
Fender	C15 ~ D2
Side Cover	D3
Rear Arm Suspension	D4
Drive Shaft	D5 ~ D6
Steering	D7
Front Fork	D8 ~ D9
Fuel Tank	D10 ~ D11
Seat	D12
Front Wheel	D13
Front Brake Caliper	D14
Rear Wheel	D15 ~ E2
Rear Brake Caliper	E3

Steering Handle · Cable	E4
Front Master Cylinder	E5
Stand · Footrest	E6 ~ E7
Rear Master Cylinder	E8 ~ E9
Cowling 1	E10 ~ E11
Generator	E12
Pick Up Coil · Governor	E13
Starting Motor	E14
Flasher Light	E15
Meter	F2
Headlight	F3
Taillight	F4
Handle Switch · Lever	F5
Electrical 1	F6
Electrical 2	F7 ~ F8

INDIVIDUAL SPEC.

FOR ENGLAND

Alternate (Electrical)	F10
------------------------------	-----

FOR FINLAND

Alternate (Chassis)	F12
---------------------------	-----

INDEX (GENERAL SPEC.)

NUMERICAL INDEX	K2 ~ K5
-----------------------	---------

INDEX (INDIVIDUAL SPEC.)

NUMERICAL INDEX	L2
-----------------------	----

FIG. 1 CYLINDER HEAD

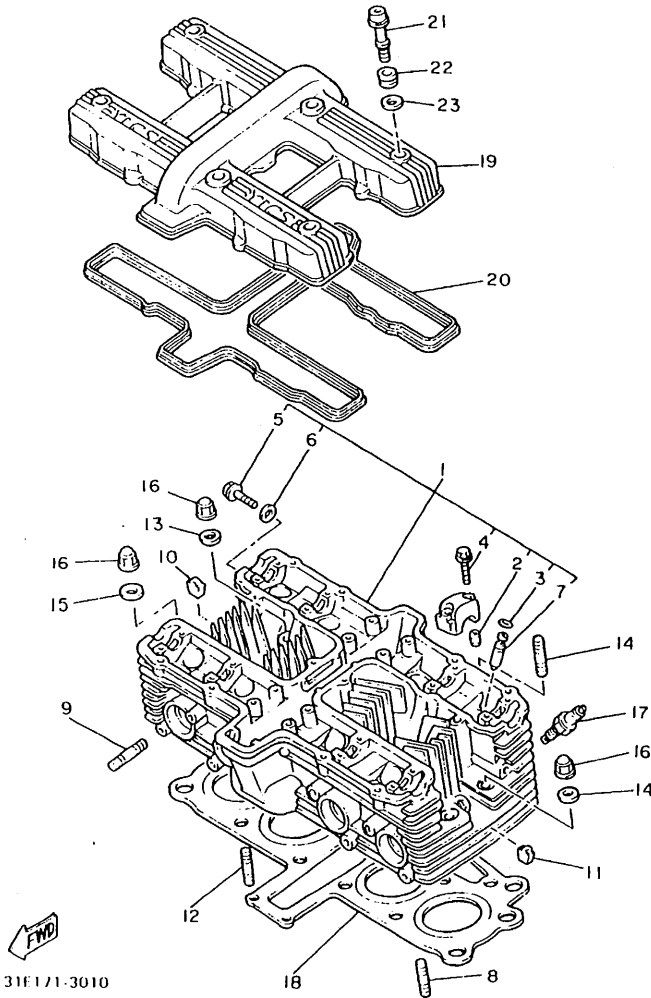

31F171-3010

REF. NO.	PART NO.	DESCRIPTION	Q'TY	REMARKS
1	31A-11101-01	CYLINDER HEAD ASSY	1	
2	99510-08016	.PIN, dowel	16	
3	93440-12052	.CIRCLIP	8	
4	90105-06153	.BOLT, washer based	24	
5	90153-06029	.SCREW, hexagon	1	
6	90430-06014	.GASKET	1	
7	4H7-11133-10	.GUIDE, intake valve	8	
8	95611-06625	BOLT, stud	2	
9	90116-06466	BOLT, stud	8	
10	434-11161-00	ABSORBER 1	8	
11	4H7-11161-00	ABSORBER 1	14	
12	95611-06630	BOLT, stud	2	
13	95621-08330	BOLT, stud	2	
14	90201-10131	WASHER, plate	10	
15	90201-10128	WASHER, plate	2	
16	90176-10049	NUT, crown	12	
17	94701-00219	PLUG, spark (NGK BPR8ES)	4	
18	58L-11181-00	GASKET, cylinder head 1	1	
19	42N-11191-00	COVER, cylinder head 1	1	
20	31A-11193-00	GASKET, head cover 1	1	
21	90109-064F0	BOLT	8	
22	2GH-1111G-00	RUBBER, mount 1	8	
23	90209-11262	WASHER	8	

FIG. 2 CYLINDER

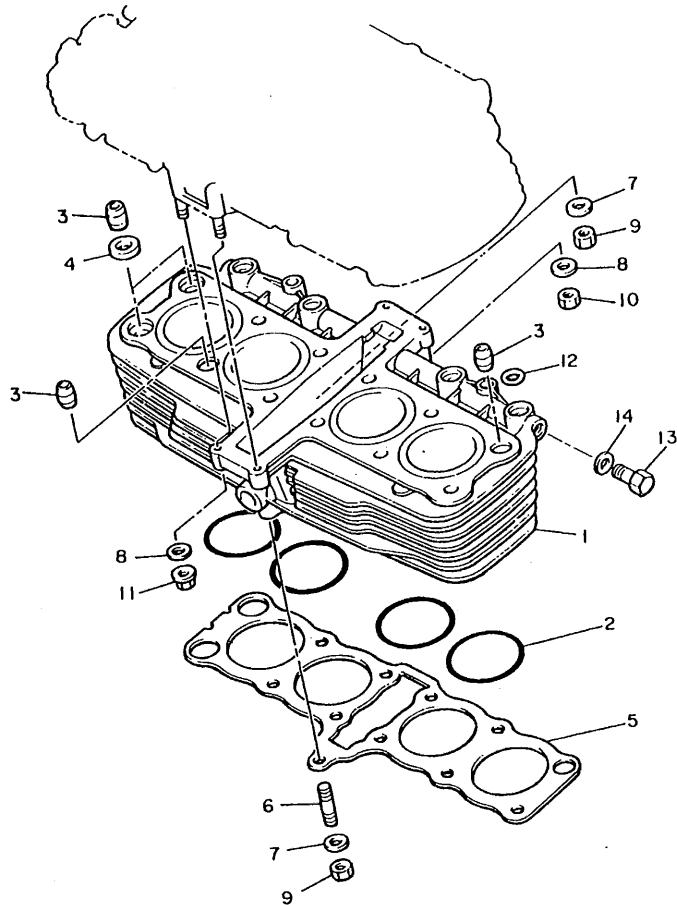

REF. NO.	PART NO.	DESCRIPTION	Q'TY	REMARKS
1	58L-11310-00	CYLINDER	1	
2	93210-71462	O-RING	4	
3	99530-14016	PIN, dowel	4	
4	90430-14131	GASKET	2	
5	4BB-11351-00	GASKET, cylinder	1	
6	95621-08335	BOLT, stud	1	
7	90201-084G3	WASHER, plate	3	
8	92901-06600	WASHER, plate	4	
9	95333-08600	NUT	3	
10	95311-06600	NUT	2	
11	90179-06499	NUT	2	
12	93210-09443	O-RING	4	
13	90340-12062	PLUG, straight screw	2	
14	90201-12790	WASHER, plate	2	



31E171-3020

FIG. 3 CRANKSHAFT • PISTON

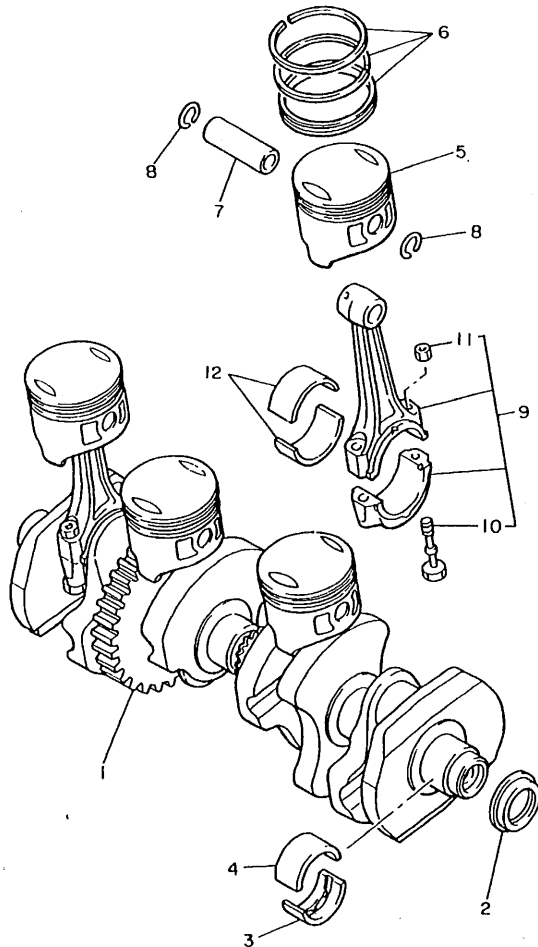

REF. NO.	PART NO.	DESCRIPTION	Q'TY	REMARKS
1	31A-11411-00	CRANKSHAFT	1	
2	93101-32144	OIL SEAL	1	
3	4H7-11416-01	PLANE BEARING, crankshaft 1	5	UR BLUE
	4H7-11416-11	PLANE BEARING, crankshaft 1	5	UR BLACK
	4H7-11416-21	PLANE BEARING, crankshaft 1	5	UR BROWN
	4H7-11416-31	PLANE BEARING, crankshaft 1	5	UR GREEN
	4H7-11416-41	PLANE BEARING, crankshaft 1	5	UR YELLOW
4	5G2-11418-00	PLANE BEARING, crankshaft 3	5	UR BLUE
	5G2-11418-10	PLANE BEARING, crankshaft 3	5	UR BLACK
	5G2-11418-20	PLANE BEARING, crankshaft 3	5	UR BROWN
	5G2-11418-30	PLANE BEARING, crankshaft 3	5	UR GREEN
	5G2-11418-40	PLANE BEARING, crankshaft 3	5	UR YELLOW
5	58L-11631-00-E0	PISTON (STD)	4	
	58L-11636-00	PISTON (0.50MM O/S)	4	AP
	58L-11638-00	PISTON (1.00MM O/S)	4	AP
6	58L-11610-00	PISTON RING SET (STD)	4	
	58L-11610-20	PISTON RING SET (0.50MM O/S)	4	AP
	58L-11610-40	PISTON RING SET (1.00MM O/S)	4	AP
7	58L-11633-00	PIN, piston	4	
8	93450-17044	CIRCLIP	8	
9	31A-11650-00	CONNECTING ROD ASSY	4	
10	12R-11654-00	.BOLT, connecting rod	2	
11	90179-08327	.NUT	2	
12	31A-11656-00	PLANE BEARING, connecting rod	8	UR BLUE
	31A-11656-10	PLANE BEARING, connecting rod	8	UR BLACK
	31A-11656-20	PLANE BEARING, connecting rod	8	UR BROWN
	31A-11656-30	PLANE BEARING, connecting rod	8	UR GREEN



31E171-3031

FIG. 4 VALVE

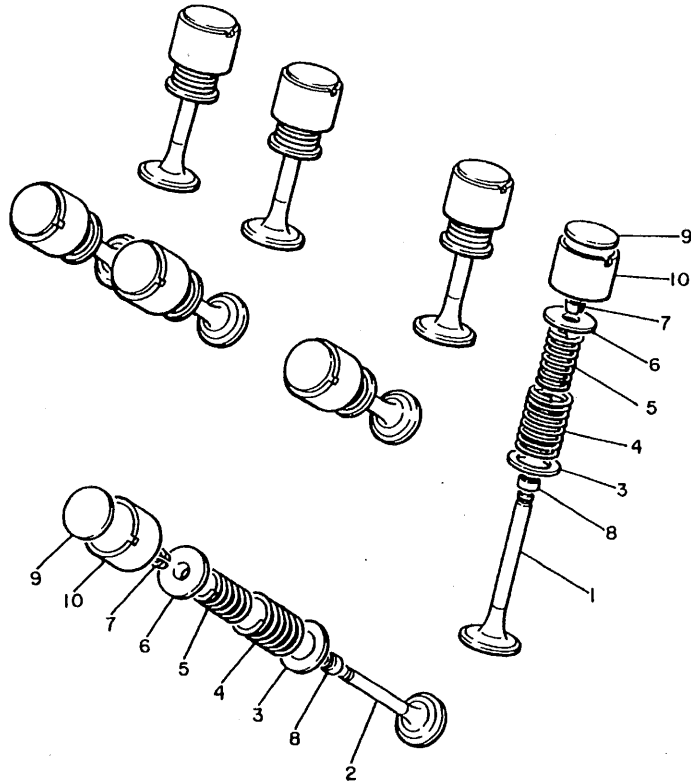

REF. NO.	PART NO.	DESCRIPTION	Q'TY	REMARKS
1	31A-12111-00	VALVE, intake	4	
2	31A-12121-00	VALVE, exhaust	4	
3	4H7-12116-00	SEAT, valve spring	8	
4	4H7-12113-00	SPRING, valve inner	8	
5	4H7-12114-00	SPRING, valve outer	8	
6	2F3-12117-00	RETAINER, valve spring	8	
7	1J7-12118-00	COTTER, valve	16	
8	1J7-12119-01	SEAL, valve stem	8	
9	1J7-12169-01	PAD, adjusting (2.00)	8	UR
	1J7-12169-11	PAD, adjusting (2.05)	8	UR
	1J7-12169-21	PAD, adjusting (2.10)	8	UR
	1J7-12169-31	PAD, adjusting (2.15)	8	UR
	1J7-12169-41	PAD, adjusting (2.20)	8	UR
	1J7-12169-51	PAD, adjusting (2.25)	8	UR
	1J7-12169-61	PAD, adjusting (2.30)	8	UR
	1J7-12169-71	PAD, adjusting (2.35)	8	UR
	1J7-12169-81	PAD, adjusting (2.40)	8	UR
	1J7-12169-91	PAD, adjusting (2.45)	8	UR
	1J7-12169-A1	PAD, adjusting (2.50)	8	UR
	1J7-12169-E1	PAD, adjusting (2.55)	8	UR
	1J7-12169-F1	PAD, adjusting (2.60)	8	UR
	1J7-12169-G1	PAD, adjusting (2.65)	8	UR
	1J7-12169-H1	PAD, adjusting (2.70)	8	UR
	1J7-12169-J1	PAD, adjusting (2.75)	8	UR
	1J7-12169-K1	PAD, adjusting (2.80)	8	UR
	1J7-12169-L1	PAD, adjusting (2.85)	8	UR
	1J7-12169-M1	PAD, adjusting (2.90)	8	UR
	1J7-12169-N1	PAD, adjusting (2.95)	8	UR

4H7110-0050

FIG. 4 VALVE

REF. NO.	PART NO.	DESCRIPTION	Q'TY	REMARKS
9	1J7-12169-R1	PAD, adjusting (3.00)	8	UR
	1J7-12169-T1	PAD, adjusting (3.05)	8	UR
	1J7-12169-U1	PAD, adjusting (3.10)	8	UR
	1J7-12169-V1	PAD, adjusting (3.15)	8	UR
	1J7-12169-W1	PAD, adjusting (3.20)	8	UR
10	31A-12153-00-E0	LIFTER, valve	8	UR
	4H7-12153-01-J0	LIFTER, valve (O/S)	1	UR GREEN

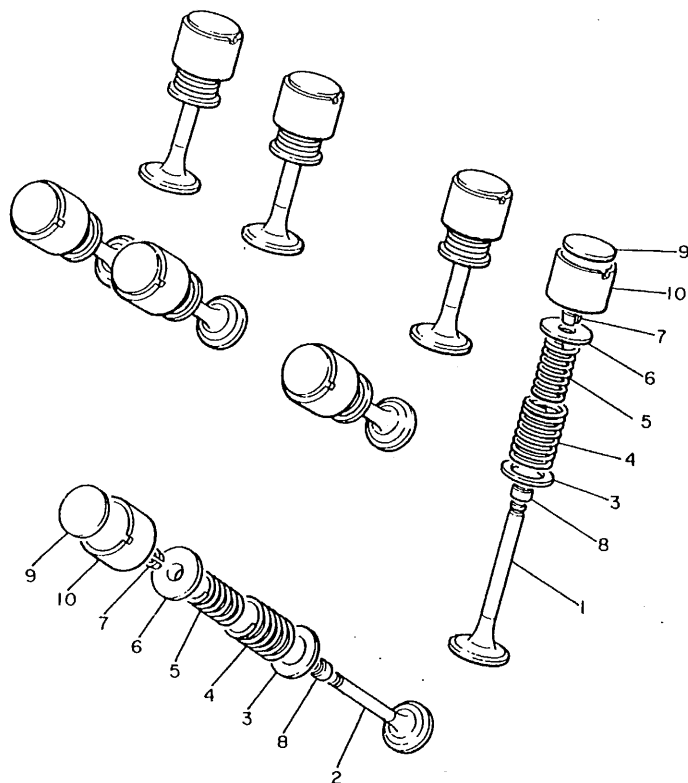

4H7110-0050

B6

FIG. 5 CAMSHAFT • CHAIN

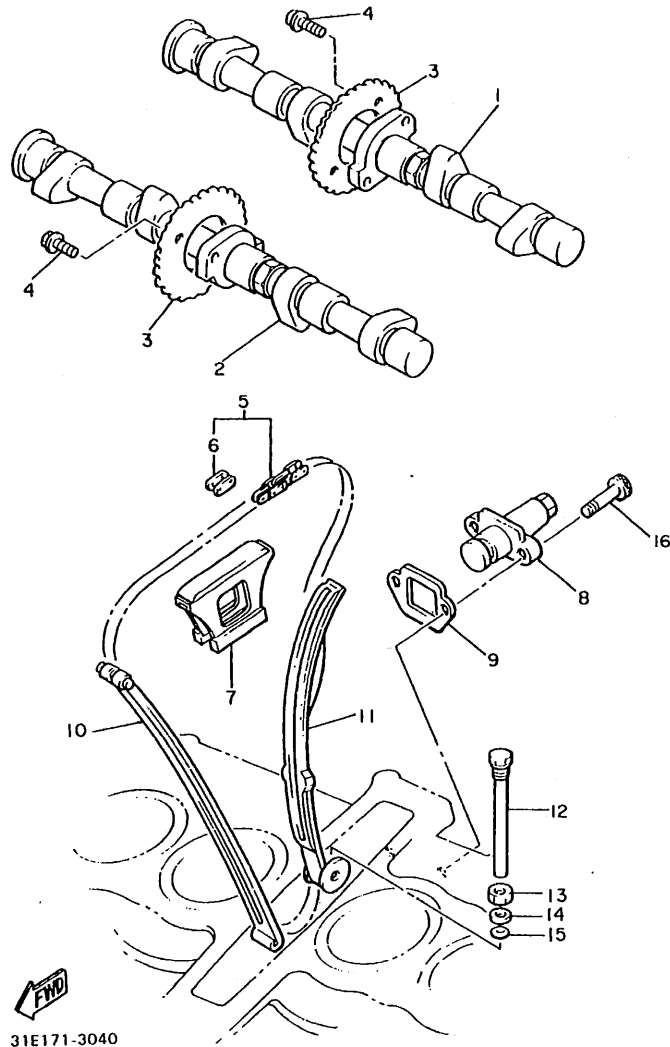

REF. NO.	PART NO.	DESCRIPTION	Q'TY	REMARKS
1	31A-12171-00	CAMSHAFT 1	1	
2	31A-12181-00	CAMSHAFT 2	1	
3	4G0-12176-01	SPROCKET, cam_chain	2	
4	90105-07087	BOLT, washer based	4	
5	94580-58120	CHAIN (DID 219FTS-120L)	1	
6	94681-01021	JOINT, chain	1	
7	4H7-12241-00	GUIDE, stopper 2	1	
8	12R-12210-00	TENSIONER ASSY, cam chain	1	
9	3YX-12213-00	GASKET, tensioner case	1	
10	4H7-12251-00	DAMPER, chain 1	1	
11	4H7-12252-00	DAMPER, chain 2	1	
12	90109-10570	BOLT	1	
13	95303-10700	NUT	1	
14	92901-08600	WASHER, plate	1	
15	93210-08006	O-RING	1	
16	91311-06025	BOLT	2	



31E171-3040

FIG. 6 OIL PUMP

REF. NO.	PART NO.	DESCRIPTION	QTY	REMARKS
1	5G2-13300-00	OIL PUMP ASSY	1	
2	5G2-13355-00	.SPROCKET, driven	1	
3	90105-06154	.BOLT, washer based	1	
4	90110-06035	BOLT, hexagon socket head	2	
5	4H7-13327-00	COVER, pump gear	1	
6	4H7-13328-00	GROMMET, gear cover	1	
7	93210-18319	O-RING	1	
8	91316-06025	BOLT	1	
9	94580-25062	CHAIN (DID25 62L)	1	
10	4H7-13354-00	SPROCKET, drive (25T)	1	
11	93315-23208	.BEARING, cylindrical	1	

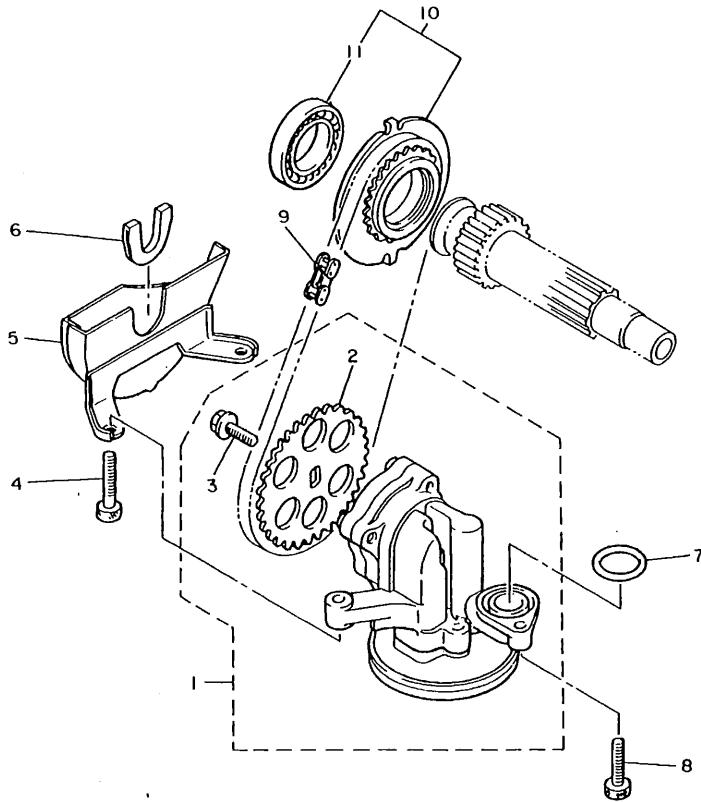

2HL300-7060

FIG. 7 OIL COOLER

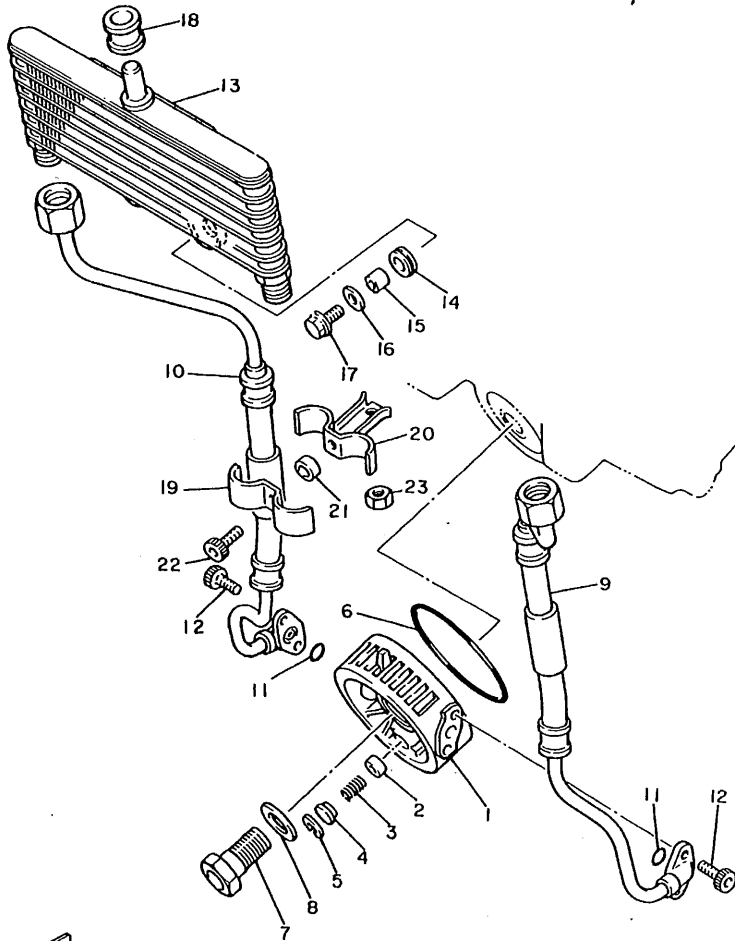

31E171-3080

REF. NO.	PART NO.	DESCRIPTION	Q'TY	REMARKS
1	5N1-13461-01	PLATE, adaptor	1	
2	2H9-13493-00	PLUNGER	1	
3	90501-12413	SPRING, compression	1	
4	90209-06173	WASHER	1	
5	99009-17500	CIRCLIP	1	
6	93210-87723	O-RING	1	
7	90401-20089	BOLT, union	1	
8	90201-25526	WASHER, plate (T2.0)	1	
9	31A-13464-01	HOSE, oil 1	1	
10	31A-13465-01	HOSE, oil 2	1	
11	93210-10197	O-RING	2	
12	91316-06016	BOLT	4	
13	31A-13470-01	OIL COOLER ASSY	1	
14	90480-15235	GROMMET	2	
15	90387-060A7	COLLAR	2	
16	90209-06174	WASHER	2	
17	95826-06020	BOLT, flange	2	
18	90480-16284	GROMMET	1	
19	90462-10066	CLAMP	1	
20	90462-10067	CLAMP	1	
21	90387-07598	COLLAR	1	
22	91316-06025	BOLT	1	
23	95311-08700	NUT	1	

FIG. 8 OIL CLEANER

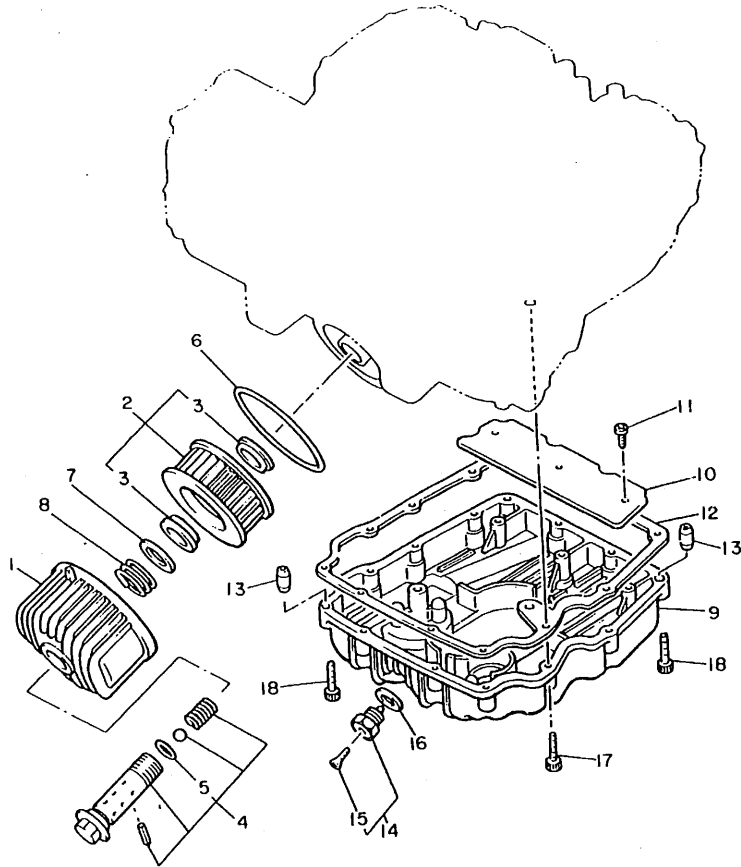

REF. NO.	PART NO.	DESCRIPTION	Q'TY	REMARKS
1	4H7-13447-00	COVER, oil element	1	
2	1L9-13441-11	ELEMENT, oil cleaner	1	
3	90480-23193	.GROMMET	2	
4	1L9-13340-01	BY-PASS VALVE ASSY	1	
5	93210-16629	.O-RING	1	
6	93210-87723	O-RING	1	
7	90201-21608	WASHER, plate	1	
8	90501-20422	SPRING, compression	1	
9	31A-13417-00	COVER, strainer	1	
10	4H7-13337-00	PLATE, baffle lower	1	
11	98501-06010	SCREW, pan head	3	
12	4BB-13414-00	GASKET, strainer cover	1	
13	99510-08016	PIN, dowel	2	
14	3VD-13455-00	PLUG	1	
15	98901-06008	.SCREW, bind	1	
16	214-11198-01	GASKET	1	
17	91311-06030	BOLT	11	
18	91311-06040	BOLT	2	



42N300-4080

FIG. 9 INTAKE

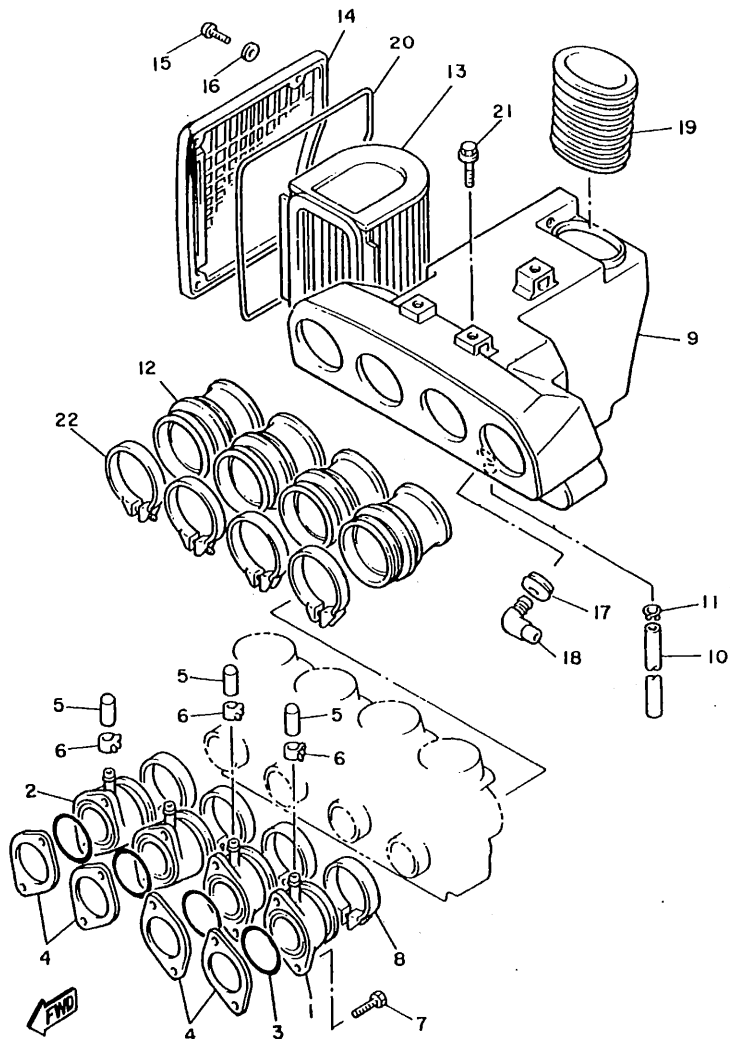

48B351-1090

REF. NO.	PART NO.	DESCRIPTION	Q'TY	REMARKS
1	31A-13586-00	JOINT, carburetor 1	2	
2	31A-13596-00	JOINT, carburetor 2	2	
3	93210-37532	O-RING	4	
4	48B-13556-00	GASKET, manifold	4	
5	16G-13569-00	PLUG, blind	3	
6	90467-10039	CLIP	3	
7	91316-06020	BOLT	8	
8	90460-52264	CLAMP, hose	4	
9	31A-14401-00	AIR CLEANER CASE ASSY	1	
10	90445-11182	HOSE	1	
11	90467-09006	CLIP	1	
12	31A-14453-00	JOINT, air cleaner 1	4	
13	31A-14451-00	ELEMENT, air cleaner	1	
14	31A-14412-00	CAP, cleaner case 1	1	
15	98501-06020	SCREW, pan head	3	
16	92901-06600	WASHER, plate	3	
17	31A-14435-00	GROMMET	1	
18	31A-14419-00	PIPE	1	
19	32F-14437-00	DUCT	1	
20	31A-14452-00	SEAL	1	
21	90119-06029	BOLT, with washer	3	
22	90460-58015	CLAMP, hose	4	

FIG. 10 CARBURETOR

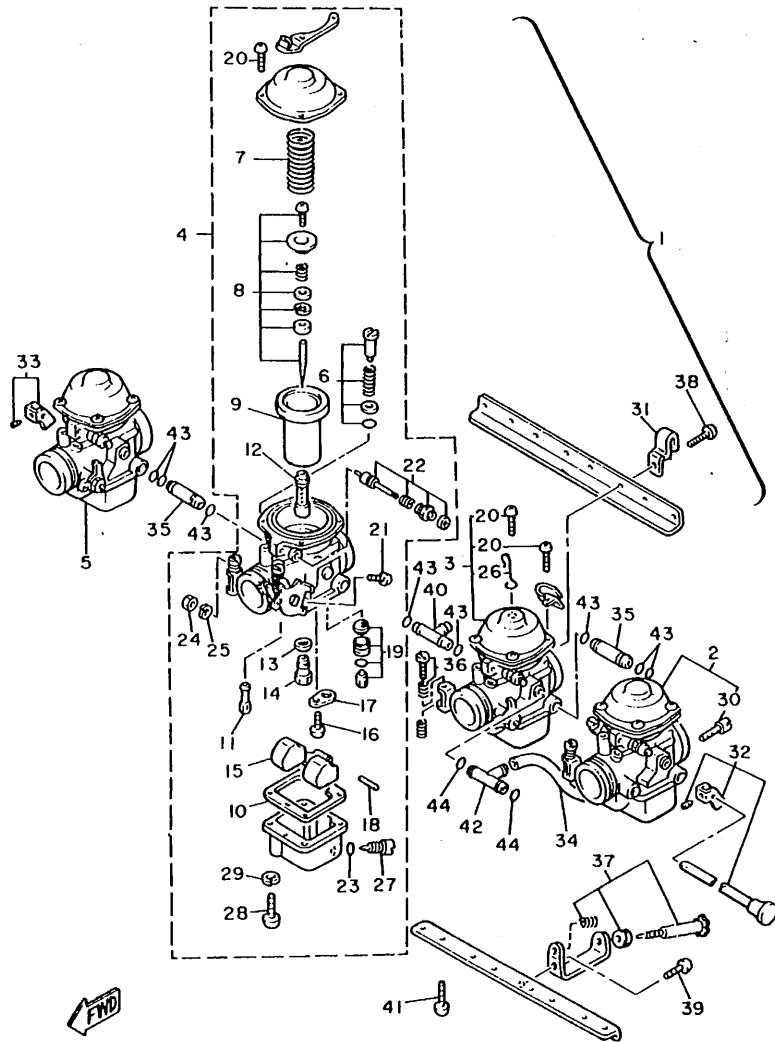

3NG351-0100

REF. NO.	PART NO.	DESCRIPTION	Q'TY	REMARKS
1	4BB-14900-00	CARBURETOR ASSY	1	
2	58L-14901-10	..CARBURETOR ASSY 1	1	
3	58L-14902-10	..CARBURETOR ASSY 2	1	
4	58L-14903-10	..CARBURETOR ASSY 3	1	
5	58L-14904-10	..CARBURETOR ASSY 4	1	
6	12R-14105-00	..ILOT SCREW SET	4	
7	3G1-14933-00	..SPRING, diaphragm	4	
8	36Y-1490J-00	..NEEDLE SET	4	
9	4BB-14940-00	..DIAPHRAGM ASSY	4	
10	3XW-14984-00	..GASKET, float chamber	4	
11	4G0-14142-40	..JET, pilot (# 40)	4	
12	16H-14941-90	..NOZZLE, main	4	
13	137-14153-00	..WASHER, main jet	4	
14	620-1423A-20	..JET, main (#100)	4	
15	3H5-14985-00	..FLOAT	4	
16	98501-04006	..SCREW, pan head	4	
17	2H0-14146-00	..PLATE	4	
18	537-14186-00	..PIN, float	4	
19	25G-14107-23	..NEEDLE VALVE SET	4	
20	98580-05010	..SCREW, pan head	16	
21	98302-05006	..SCREW, cylinder head	4	
22	58L-1410A-00	..STARTER SET	4	
23	214-14147-00	..O-RING	4	
24	812-14594-00	..NUT	3	
25	92990-08100	..WASHER, spring	3	
26	90462-13032	..CLAMP	1	
27	2L1-14191-00	..PLUG, drain	4	
28	98501-05016	..SCREW, pan head	16	

FIG. 10 CARBURETOR

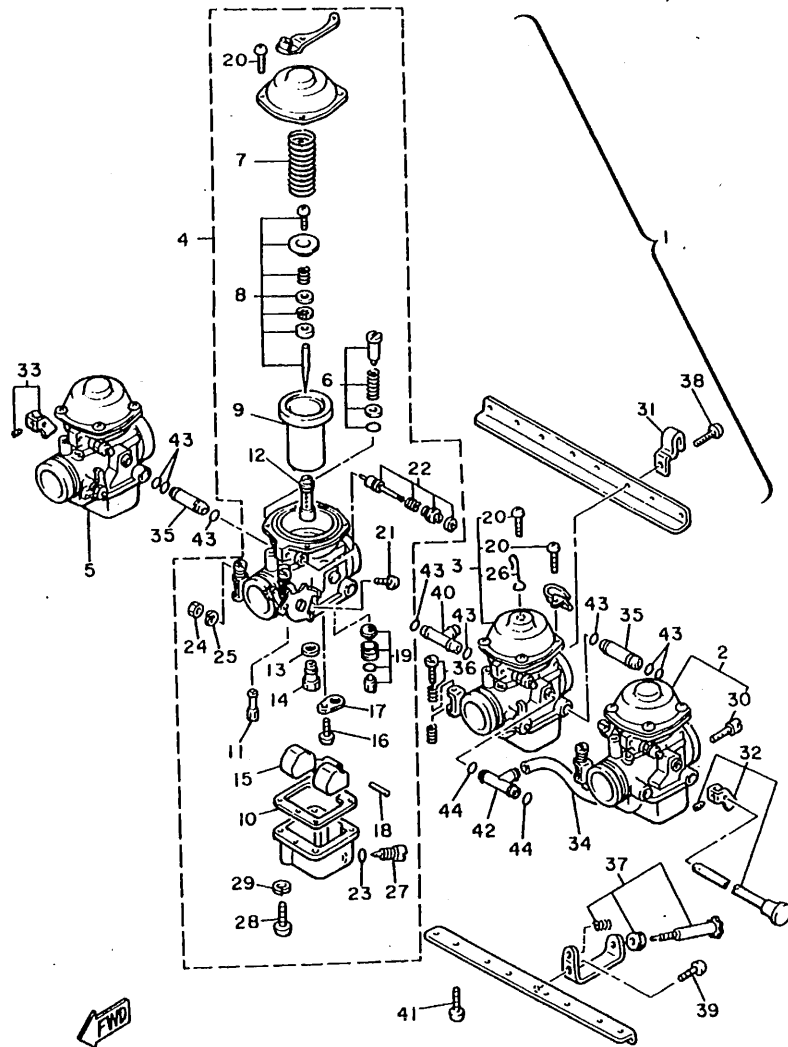

3NG351-0100

REF. NO.	PART NO.	DESCRIPTION	Q'TY	REMARKS
29	92901-05100	..WASHER, spring	16	
30	3G2-14231-32	..JET, main (#160)	4	
31	49A-14139-00	..CLIP, pipe	1	
32	58L-1490L-00	..STARTER LEVER SET, 1	1	
33	31A-1490M-00	..STARTER LEVER SET, 2	3	
34	3GM-14197-00	..PIPE	2	
35	31A-14988-00	..PIPE, starter connecting	2	
36	31A-1490K-00	..STOP SCREW SET	3	
37	31A-14103-00	..THROTTLE SCREW SET	1	
38	98580-05010	..SCREW, pan head	8	
39	4U8-14122-00	..SCREW, throttle	1	
40	1J7-14988-00	..NIPPLE	1	
41	97801-06014	..SCREW, pan head	8	
42	17A-14251-00	..NIPPLE	2	
43	36Y-14147-00	..O-RING	8	
44	822-14147-00	..O-RING	4	

FIG. 11 EXHAUST

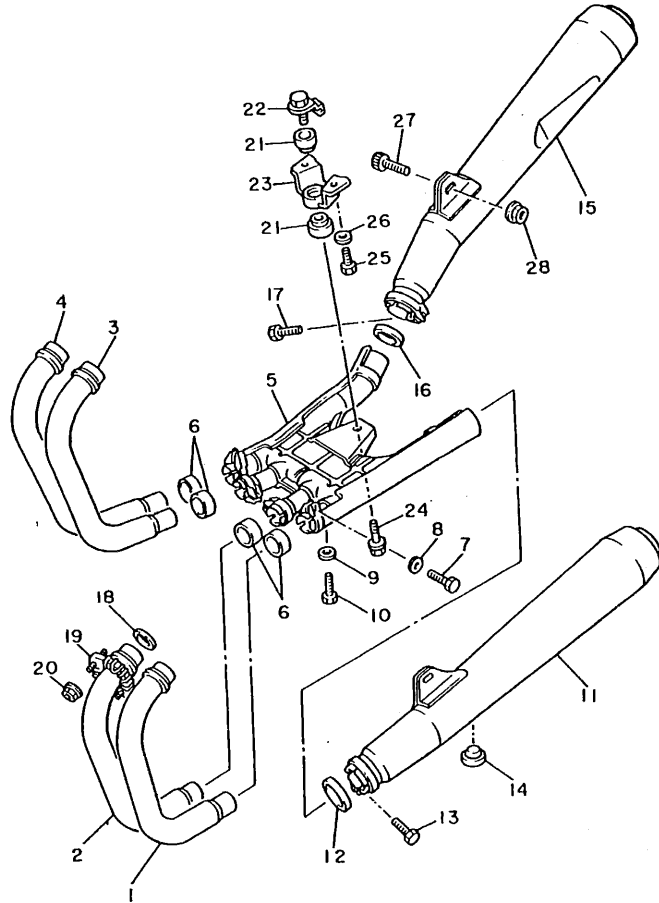

FRONT
48B332-1110

REF. NO.	PART NO.	DESCRIPTION	Q'TY	REMARKS
1	58L-14611-00	PIPE, exhaust 1	1	
2	58L-14621-00	PIPE, exhaust 2	1	
3	58L-14631-00	PIPE, exhaust 3	1	
4	58L-14641-00	PIPE, exhaust 4	1	
5	58L-14615-00	JOINT, exhaust 1	1	
6	3XW-14755-00	GASKET, muffler	4	
7	95026-08025	BOLT	4	
8	92901-08600	WASHER, plate	4	
9	92906-06600	WASHER, plate	4	
10	90101-06576	BOLT	4	
11	32F-14711-00	MUFFLER 1	1	
12	3JJ-14653-00	GASKET, muffler	1	
13	95023-08025	BOLT	1	
14	1A0-27114-00	STOPPER, main stand	1	
15	32F-14721-00	MUFFLER 2	1	
16	3JJ-14653-00	GASKET, muffler	1	
17	95023-08025	BOLT	1	
18	4BR-14613-00	GASKET, exhaust pipe	4	
19	31A-14612-00	NUT, ring	4	
20	90179-06499	NUT	8	
21	36Y-14747-00	DAMPER, muffler	2	
22	1AE-14638-00	COLLAR	1	
23	4K0-14791-00	STAY, muffler	1	
24	95811-10040	BOLT, flange	1	
25	97011-08025	BOLT	2	
26	92901-08600	WASHER, plate	2	
27	91311-10025	BOLT	2	
28	95701-10500	NUT, flange	2	

FIG. 12 CRANKCASE

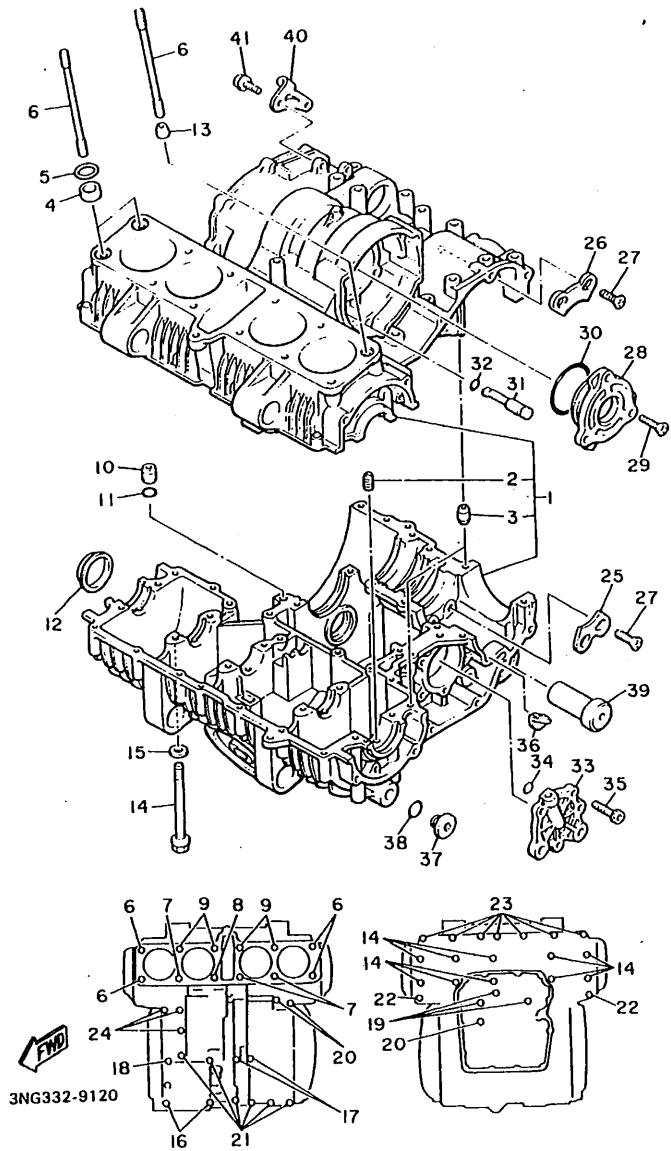

REF. NO.	PART NO.	DESCRIPTION	Q'TY	REMARKS
1	31A-15100-02	CRANKCASE ASSY	1	
2	4H7-15138-00	.NOZZLE 1	3	
3	99510-12016	.PIN, dowel	3	
4	90387-16547	COLLAR	2	
5	93210-18322	O-RING	2	
6	90116-10330	BOLT, stud	4	
7	90116-10329	BOLT, stud	3	
8	90116-10328	BOLT, stud	1	
9	4H7-11363-00	BOLT, cylinder holding 3	4	
10	99510-12016	PIN, dowel	1	
11	93210-11124	O-RING	1	
12	4H7-15167-10	PLUG, blind 1	1	
13	99510-12016	PIN, dowel	3	
14	95811-08105	BOLT, flange	10	
15	90201-094G1	WASHER, plate	8	
16	95811-08065	BOLT, flange	2	
17	95811-06135	BOLT, flange	2	
18	95811-06120	BOLT, flange	1	
19	95811-06080	BOLT, flange	3	
20	95811-06070	BOLT, flange	3	
21	95811-06060	BOLT, flange	6	
22	95811-06055	BOLT, flange	2	
23	95811-08045	BOLT, flange	7	
24	95811-06035	BOLT, flange	3	
25	31A-15381-00	PLATE, bearing cover	1	
26	31A-15383-00	PLATE, bearing cover	1	
27	90149-08152	SCREW	4	
28	4H7-15163-01	HOUSING, bearing 1	1	

FIG. 12 CRANKCASE

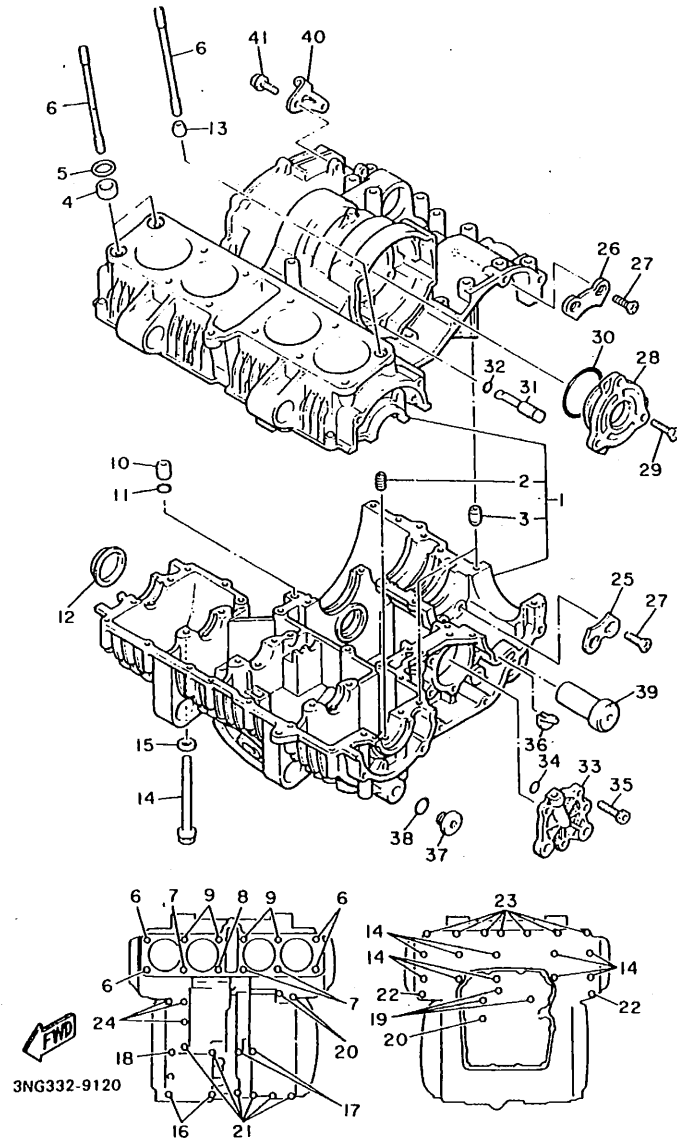

REF. NO.	PART NO.	DESCRIPTION	Q'TY	REMARKS
29	90151-06014	SCREW, countersunk	3	
30	93210-62439	O-RING	1	
31	4H7-13454-00	NOZZLE	1	
32	93210-07540	O-RING	1	
33	16G-15164-00	HOUSING, bearing 2	1	
34	93210-07438	O-RING	1	
35	91311-06020	BOLT	3	
36	4H7-15365-00	GROMMET	1	
37	4H7-15189-00	PLUG	2	
38	93210-20573	O-RING	2	
39	90387-125A2	COLLAR	2	
40	4H7-15441-01	HOLDER, clutch cable	1	
41	90110-06145	BOLT, hexagon socket head	2	

FIG. 13 CRANKCASE COVER 1

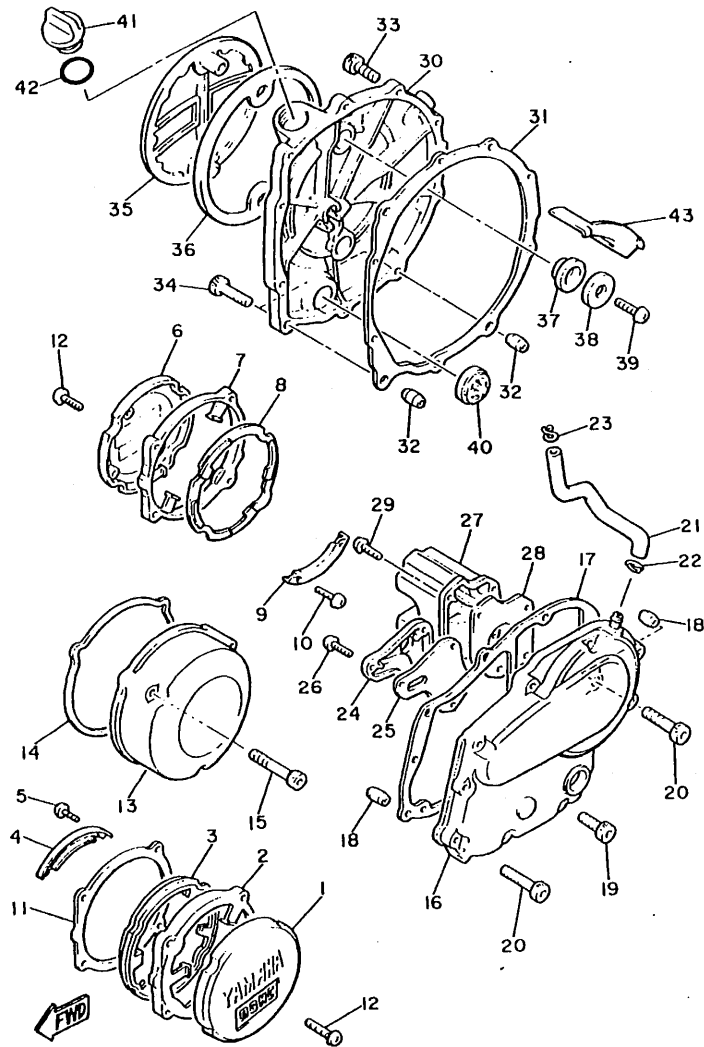

42N300-4131

REF. NO.	PART NO.	DESCRIPTION	Q'TY	REMARKS
1	22N-15416-01	COVER, oil pump	1	
2	31A-15431-01	COVER, crankcase 3	1	
3	22N-15449-00	RING, rubber	1	
4	22N-15144-00	PLATE, lock	2	
5	98501-06010	SCREW, pan head	4	
6	22N-15426-01	COVER, oil pump 2	1	
7	31A-15431-01	COVER, crankcase 3	1	
8	22N-15449-00	RING, rubber	1	
9	22N-15144-00	PLATE, lock	2	
10	98501-06010	SCREW, pan head	4	
11	4BB-15456-00	GASKET, oil pump cover 1	1	
12	98980-06020	SCREW, bind	8	
13	4H7-15415-00	COVER, generator	1	
14	4BB-15455-00	GASKET 1	1	
15	91311-06070	BOLT	3	
16	5G2-15409-00	CRANKCASE COVER ASSY	1	
17	4BB-15451-00	GASKET, crankcase cover 1	1	
18	99530-10014	PIN, dowel	2	
19	91311-06025	BOLT	8	
20	91311-06040	BOLT	2	
21	5G2-11166-00	PIPE, breather 1	1	
22	90467-14015	CLIP	1	
23	90468-08104	CLIP	1	
24	4H7-15346-00	BREATHER 1	1	
25	4BB-15457-00	GASKET	1	
26	92501-06014	SCREW, pan head	3	
27	4H7-15347-00	BREATHER 2	1	
28	4BB-15467-00	GASKET	1	

FIG. 13 CRANKCASE COVER 1

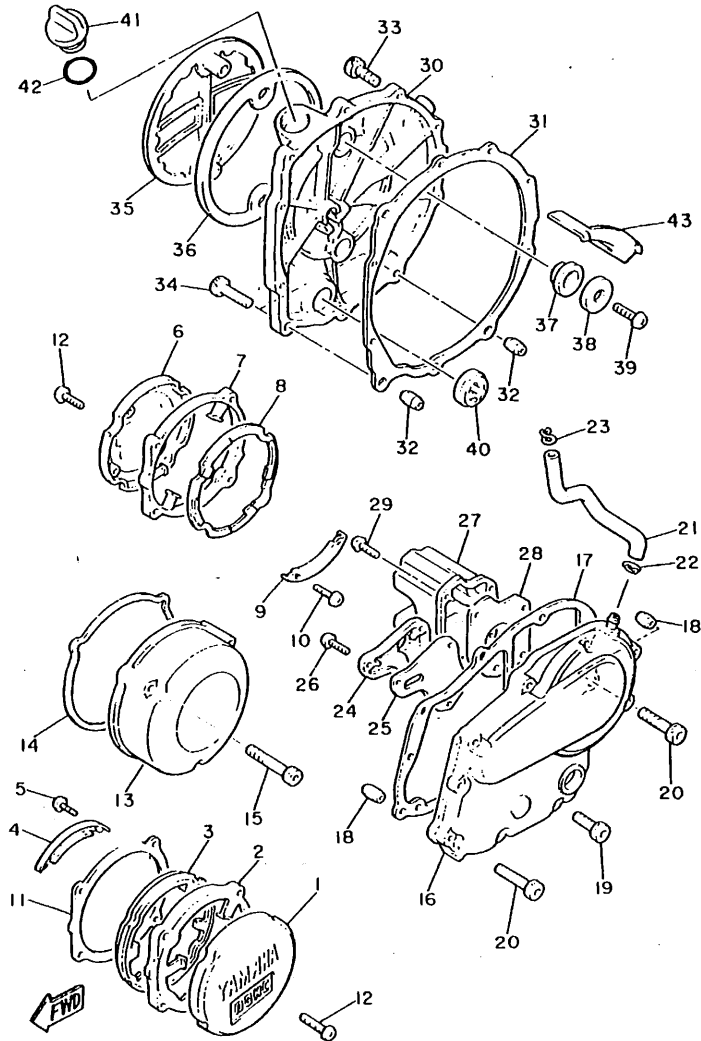

42N300-4131

REF. NO.	PART NO.	DESCRIPTION	Q'TY	REMARKS
29	92501-06014	SCREW, pan head	4	
30	4H7-15421-02	COVER, crankcase 2	1	
31	4BB-15461-00	GASKET, crankcase cover 2	1	
32	99530-10014	PIN, dowel	2	
33	91311-06025	BOLT	8	
34	91311-06040	BOLT	2	
35	5G2-15417-00	COVER, cap	1	
36	4H7-15449-00	RING, rubber	1	
37	4H7-15486-00	GROMMET	2	
38	90209-06096	WASHER	2	
39	92501-06014	SCREW, pan head	2	
40	2H7-15361-00	GAUGE, level	1	
41	2H7-15363-00	PLUG, oil	1	
42	93210-27778	O-RING	1	
43	4H7-15412-01	SCRAPER, oil	1	

FIG. 14 STARTER

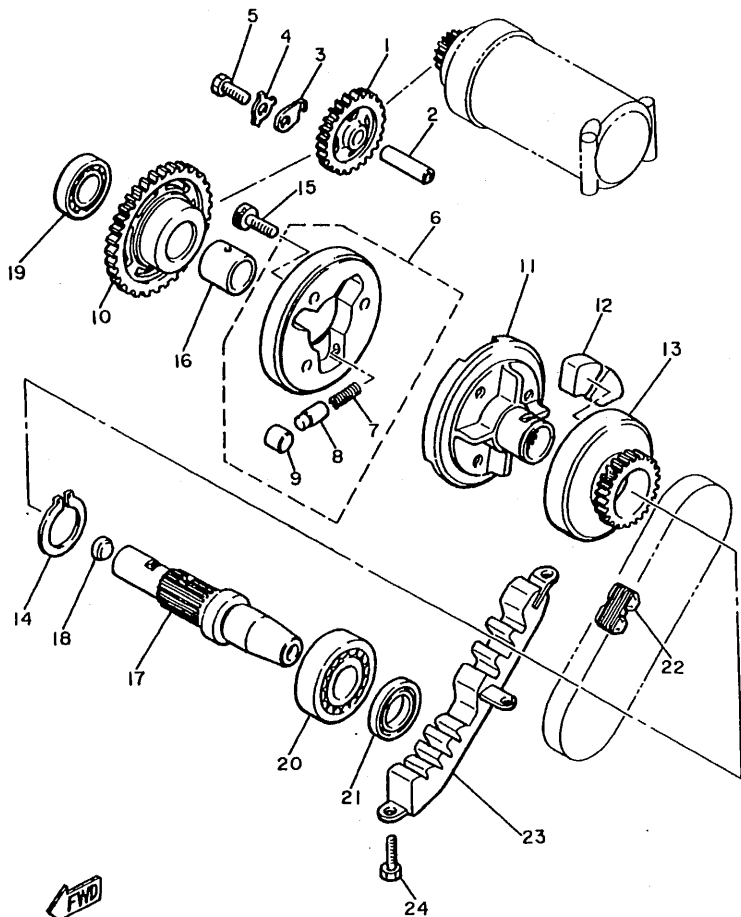

REF. NO.	PART NO.	DESCRIPTION	Q'TY	REMARKS
1	4H7-15512-00	GEAR, idler 1 (27T)	1	
2	4H7-15521-00	SHAFT 1	1	
3	2H7-15531-00	PLATE, stopper	1	
4	90215-06040	WASHER, lock	1	
5	97313-06016	BOLT	1	
6	31A-15580-00	STARTER CLUTCH OUTER ASSY	1	
7	90501-04503	.SPRING, compression	3	
8	341-15583-05	.CAP, starter clutch spring	3	
9	93615-12088	.PIN, dowel	3	
10	4H7-15517-00	GEAR, idler 2 (43T)	1	
11	4H7-15524-00	WHEEL, starter	1	
12	4H7-16155-01	ABSORBER 1	4	
13	4H7-15519-00	SPROCKET, starter (21T)	1	
14	93410-32052	CIRCLIP	1	
15	91316-08014	BOLT	3	
16	90387-202A7	COLLAR	1	
17	4H7-15522-00	SHAFT 2	1	
18	90331-12028	PLUG	1	
19	93306-00401	BEARING (B6004)	1	
20	93306-20541	BEARING (B6205)	1	
21	93102-25218	OIL SEAL	1	
22	4H7-11456-00	CHAIN, primary	1	
23	4H7-11474-01	GUIDE, upper	1	
24	97021-06014	BOLT	2	

 17Y700-2200

FIG. 15 CLUTCH

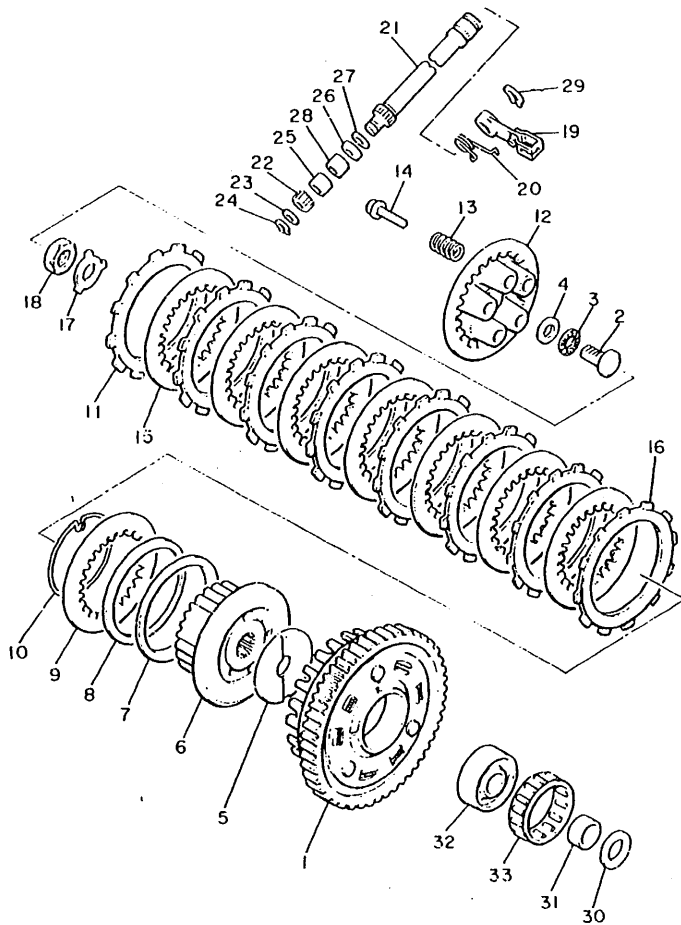

REF. NO.	PART NO.	DESCRIPTION	Q'TY	REMARKS
1	58L-16150-00	PRIMARY DRIVEN GEAR COMP.	1	
2	3LD-1637A-00	ROD, push 1	1	
3	93340-21505	BEARING, thrust	1	
4	90201-150H2	WASHER, plate	1	
5	4H7-16154-00	PLATE, thrust 1	1	
6	58L-16371-01	BOSS, clutch	1	
7	1J7-16384-00	PLATE, seat	1	
8	5G2-16383-00	SPRING, clutch boss	1	
9	168-16324-00	PLATE, clutch 1	1	
10	1J7-16385-00	RING, clutch boss	1	
11	4H7-16321-00	PLATE, friction	7	
12	58L-16351-00	PLATE, pressure 1	1	
13	90501-224A8	SPRING, compression	6	
14	90159-06092	SCREW, with washer	6	
15	31A-16325-00	PLATE, clutch 2	7	
16	31A-16321-00	PLATE, friction	1	
17	90215-20231	WASHER, lock	1	
18	90170-20327	NUT	1	
19	4H7-16340-00	PUSH LEVER ASSY	1	
20	90508-16459	SPRING, torsion	1	
21	4H7-16382-01	AXLE, push lever	1	
22	4H7-16398-00	PINION, releas (16T)	1	
23	92901-08600	WASHER, plate	1	
24	99080-07600	CIRCLIP	1	
25	93317-11020	BEARING, cylindrical	1	
26	93102-12224	OIL SEAL	1	
27	90201-12M34	WASHER, plate	1	
28	93315-11206	BEARING, cylindrical	1	

 38X010-3140

C6

FIG. 15 CLUTCH

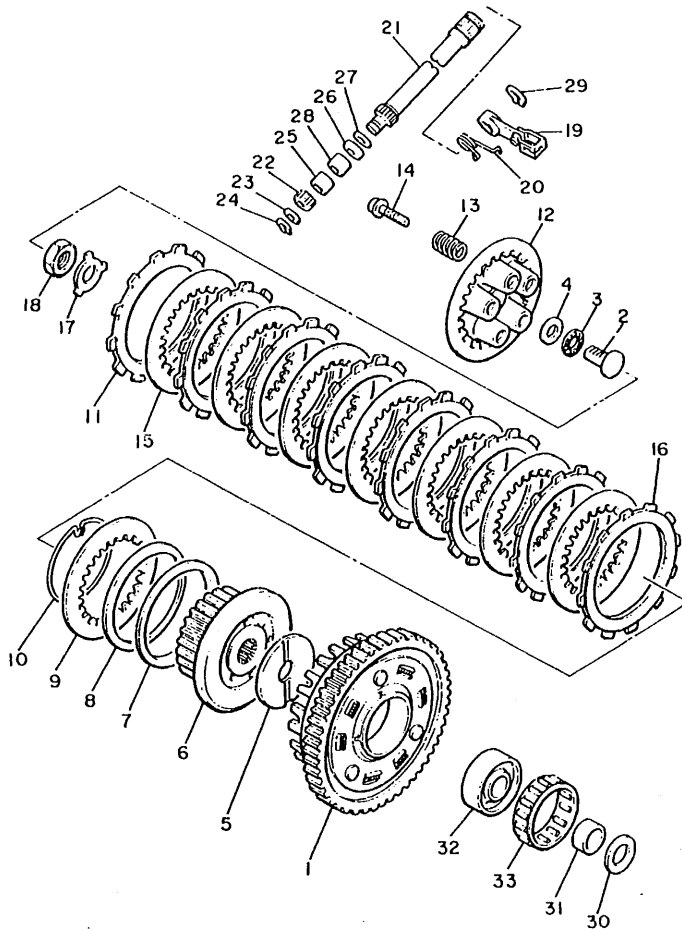

REF. NO.	PART NO.	DESCRIPTION	Q'TY	REMARKS
29	99001-09600	CIRCLIP	1	
30	2K7-16154-00	PLATE, thrust 1	1	
31	90387-252A8	COLLAR	1	
32	4H7-16181-00	SPACER 1	1	
33	93310-365H3	BEARING, cylindrical	1	



38X010-3140

FIG. 16 TRANSMISSION

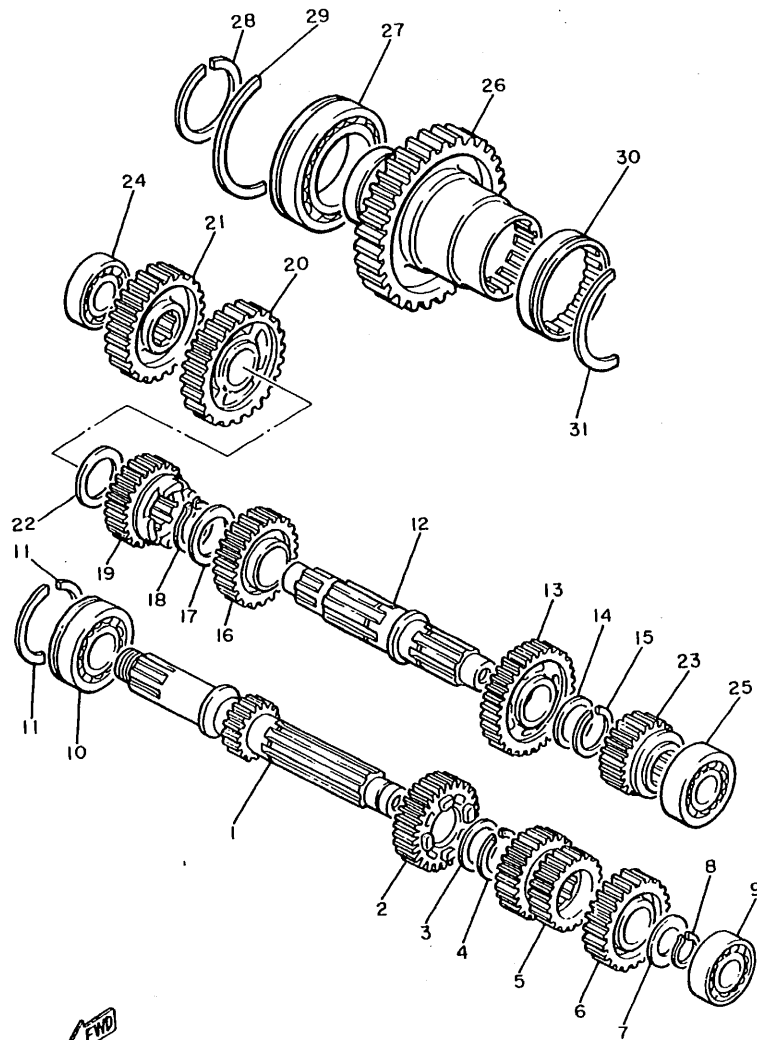

4BB300-1160

REF. NO.	PART NO.	DESCRIPTION	Q'TY	REMARKS
1	4H7-17401-00	MAIN AXLE ASSY (16T)	1	
2	4H7-17141-00	GEAR, 4th pinion (30T)	1	
3	90209-22191	WASHER	1	
4	93440-25084	CIRCLIP	1	
5	4BB-17121-00	GEAR, 2nd pinion (20/26T)	1	
6	4H7-17151-00	GEAR, 5th pinion (32T)	1	
7	90201-20276	WASHER, plate (1.0T)	1	
8	99009-20400	CIRCLIP	1	
9	93306-20465	BEARING	1	
10	93306-30528	BEARING (B6305Z)	1	
11	278-17424-01	CIRCLIP 1	2	
12	4H7-17402-01	DRIVE AXLE ASSY	1	
13	4BB-17221-00	GEAR, 2nd wheel (30T)	1	
14	90209-22252	WASHER	1	
15	93440-25084	CIRCLIP	1	
16	4BB-17231-00	GEAR, 3rd wheel (30T)	1	
17	90209-25196	WASHER	1	
18	93440-28062	CIRCLIP	1	
19	4H7-17241-00	GEAR, 4th wheel (28T)	1	
20	4H7-17211-01	GEAR, 1st wheel (35T)	1	
21	4L6-17582-00	GEAR, middle drive (37T)	1	
22	90201-243A2	WASHER, plate	1	
23	16G-17251-00	GEAR, 5th wheel (26T)	1	
24	93306-30311	BEARING	1	
25	93306-20439	BEARING	1	
26	31A-17583-00	GEAR, middle driven (48T)	1	
27	93306-91101	BEARING (B6911)	1	
28	93410-55057	CIRCLIP	1	

FIG. 16 TRANSMISSION

REF. NO.	PART NO.	DESCRIPTION	Q'TY	REMARKS
29	93440-80082	CIRCLIP	1	
30	93311-36042	BEARING, cylindrical	1	
31	93440-72049	CIRCLIP	1	

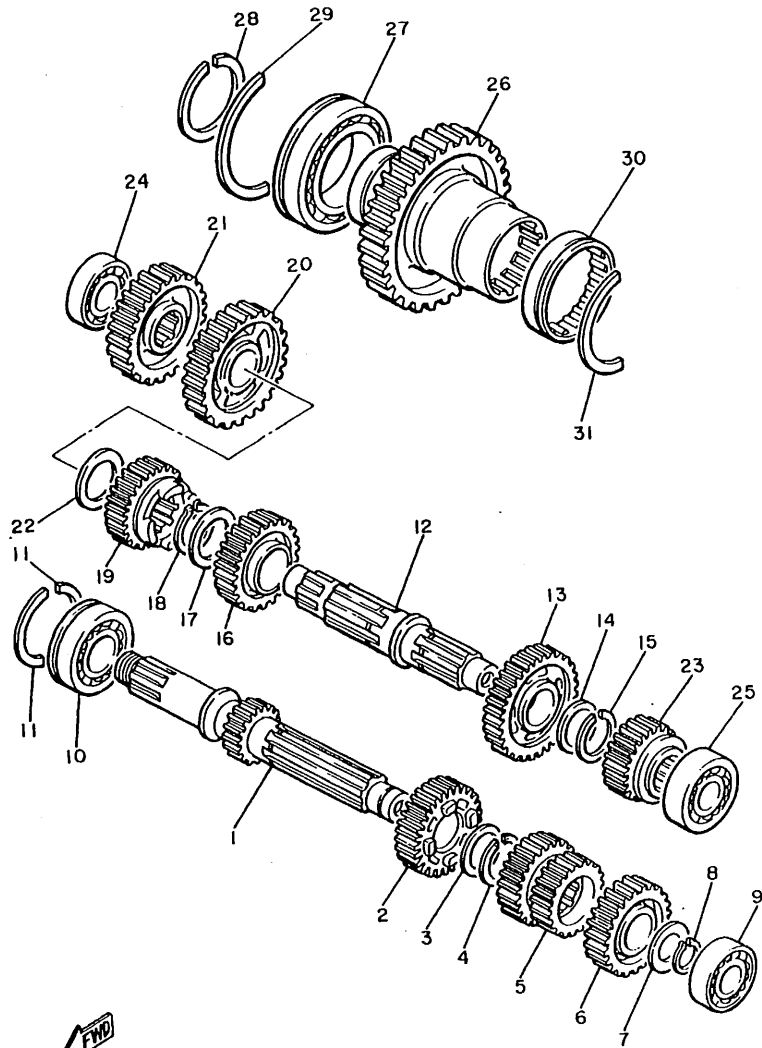

FWD

4BB300-1180

C9

FIG. 17 MIDDLE DRIVE GEAR

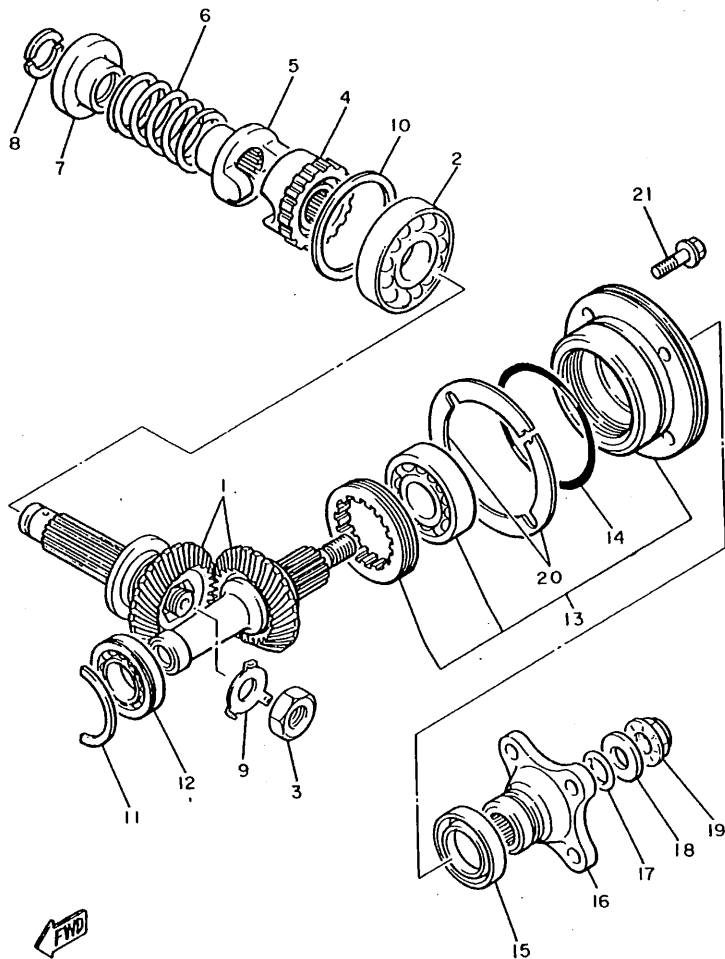

31F171-3200

REF. NO.	PART NO.	DESCRIPTION	Q'TY	REMARKS
1	31A-W1751-01	MIDDLE GEAR COMP.	1	
2	93306-20709	BEARING (B6207)	1	
3	90179-18360	NUT	1	
4	31A-17526-00	CAM, drive	1	
5	31A-17527-00	CAM, driven	1	
6	90501-70762	SPRING, compression	1	
7	4H7-17524-00	HOLDER	1	
8	3H5-17529-00	WASHER, thrust	2	
9	90215-23194	WASHER, lock	1	
10	4H7-17537-00-20	SHIM, thrust (0.20T)	1	UR
	4H7-17537-00-30	SHIM, thrust (0.30T)	1	UR
	4H7-17537-00-40	SHIM, thrust (0.40T)	1	UR
	4H7-17537-00-40	SHIM, thrust (0.40T)	1	UR
11	93440-47081	CIRCLIP	1	
12	93306-00508	BEARING (B6005)	1	
13	31A-W1752-00	HOUSHING COMP	1	
14	93210-71360	O-RING	1	
15	93101-35097	OIL SEAL	1	
16	4H7-17555-00	FLANGE, middle gear	1	
17	93210-14359	O-RING	1	
18	90201-14633	WASHER, plate	1	
19	90179-14317	NUT	1	
20	3JB-17531-10	SHIM, pinion (0.15T)	2	UR
	4H7-17531-00-15	SHIM, pinion (0.15T)	2	UR
	3JB-17531-20	SHIM, pinion (0.20T)	2	UR
	3JB-17531-30	SHIM, pinion (0.30T)	2	UR
	4H7-17531-00-40	SHIM, pinion (0.40T)	2	UR
	4H7-17531-00-40	SHIM, pinion (0.40T)	2	UR

FIG. 17 MIDDLE DRIVE GEAR

REF. NO.	PART NO.	DESCRIPTION	Q'TY	REMARKS
21	95811-08030	BOLT, flange	4	

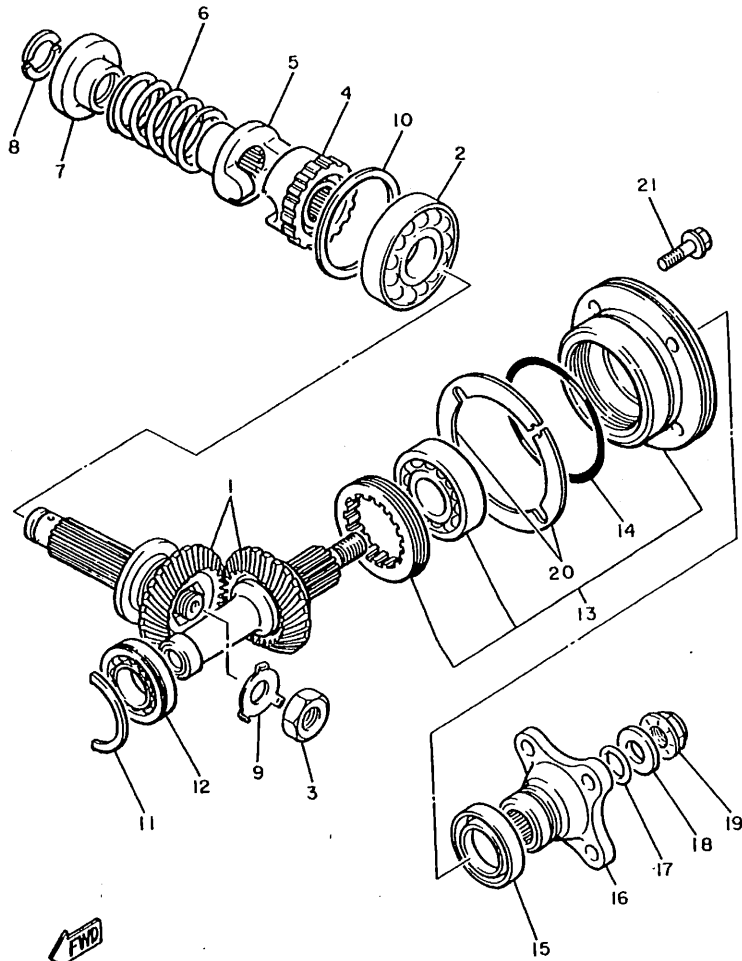

31E171-3200

C11

FIG. 18 SHIFT CAM .FORK

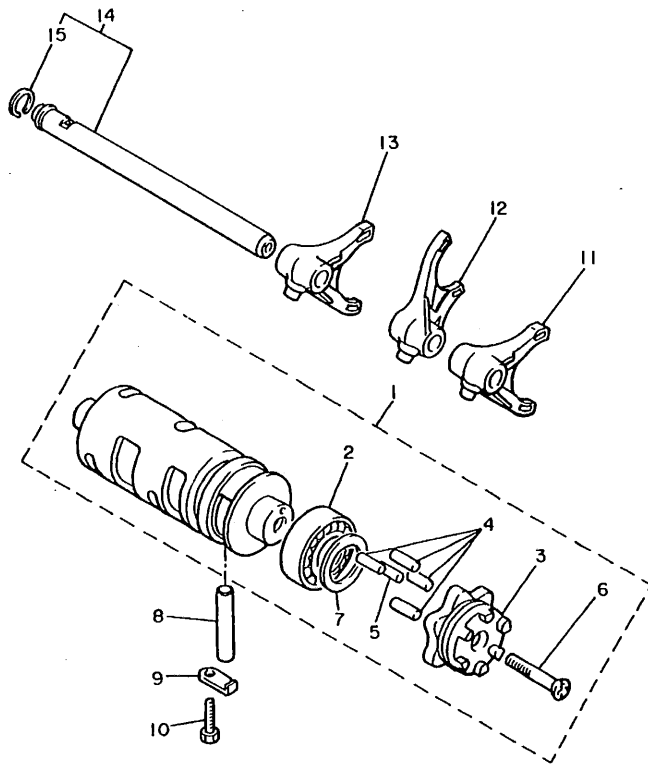

REF. NO.	PART NO.	DESCRIPTION	Q'TY	REMARKS
1	16G-18540-00	SHIFT CAM ASSY	1	
2	93306-90501	.BEARING	1	
3	16G-18185-00	.SEGMENT	1	
4	93604-16092	.PIN, dowel	4	
5	93604-10011	.PIN, dowel	1	
6	98701-05035	.SCREW, flat head	1	
7	117-15644-00	.SHIM	1	
8	93608-43157	PIN, dowel	1	
9	2H7-15531-00	PLATE, stopper	1	
10	97313-06016	BOLT	1	
11	4H7-18511-01	FORK, shift 1	1	
12	4H7-18512-01	FORK, shift 2	1	
13	4H7-18513-01	FORK, shift 3	1	
14	4H7-18531-00	BAR, shift fork guide 1	1	
15	93440-11029	.CIRCLIP	1	



16G110-3241

C12

FIG. 19 SHIFT SHAFT

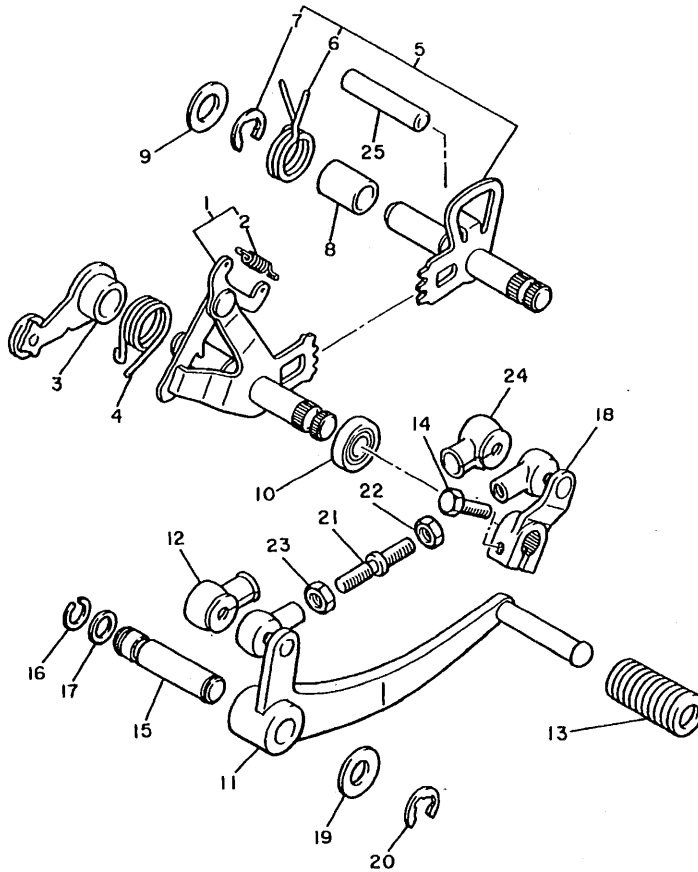

REF. NO.	PART NO.	DESCRIPTION	Q'TY	REMARKS
1	4K0-18101-01	SHIFT SHAFT ASSY	1	
2	90506-08227	.SPRING, tension	1	
3	4H7-18140-00	STOPPER LEVER ASSY	1	
4	90508-29530	SPRING, torsion	1	
5	4K0-18120-01	SHIFT LEVER ASSY	1	
6	90508-32535	.SPRING, torsion	1	
7	99006-10600	.CIRCLIP	1	
8	90387-124F4	COLLAR	1	
9	90201-12166	WASHER, plate	1	
10	93102-12106	OIL SEAL (SD 12-22-6 HS)	1	
11	41Y-18111-00	PEDAL, shift	1	
12	2H9-18154-00	COVER, dust	1	
13	132-18113-01	COVER, shift pedal	1	
14	97011-06020	BOLT	1	
15	4K0-18197-00	SHAFT	1	
16	93440-12066	CIRCLIP	1	
17	93210-09350	O-RING	1	
18	2H9-W1812-00	ARM, shift	1	
19	90201-124E4	WASHER, plate	1	
20	99006-10600	CIRCLIP	1	
21	4K0-18115-00	ROD, shift	1	
22	95303-06700	NUT	1	
23	90170-06228	NUT(COUNTER CLOCKWISE)	1	
24	2H9-18154-00	COVER, dust	1	
25	93608-50158	PIN, dowel	1	



44X171-4190

FIG. 20 FRAME

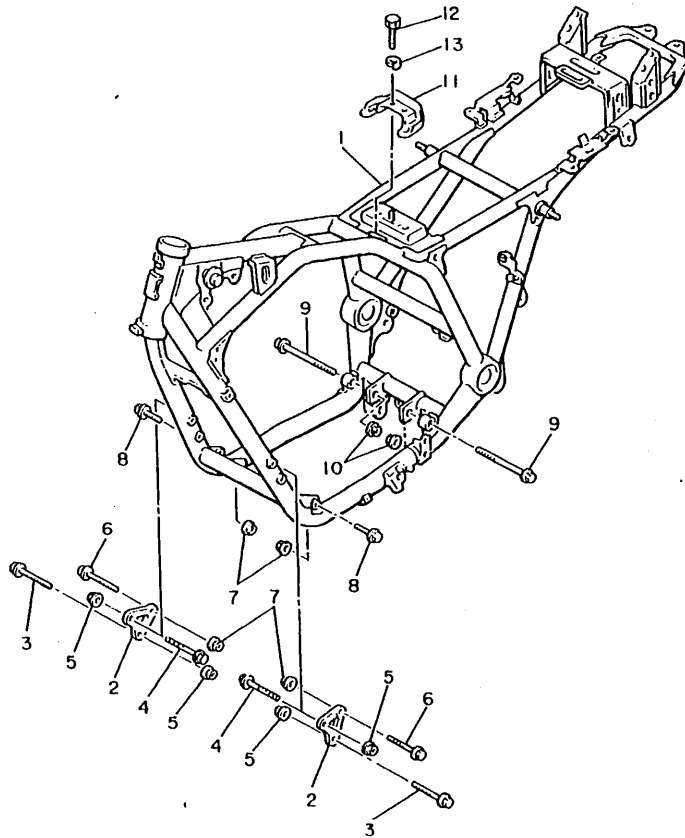

REF. NO.	PART NO.	DESCRIPTION	Q'TY	REMARKS
1	42N-21110-10-33	FRAME COMP.	1	YAMAHA BLACK
2	31A-21315-00-33	STAY, engine 2	2	YAMAHA BLACK
3	90105-08278	BOLT, washer based	2	
4	95816-08070	BOLT, flange	2	
5	90179-08246	NUT	4	
6	90105-10169	BOLT, washer based	2	
7	90179-10247	NUT	4	
8	90105-10038	BOLT, washer based	2	
9	90105-12208	BOLT, washer based	2	
10	90179-12421	NUT	2	
11	31A-21147-00	BRACKET, air cleaner 1	1	
12	97026-06012	BOLT	2	
13	92906-06100	WASHER, spring	2	



42N300-4200

FIG. 21 FENDER

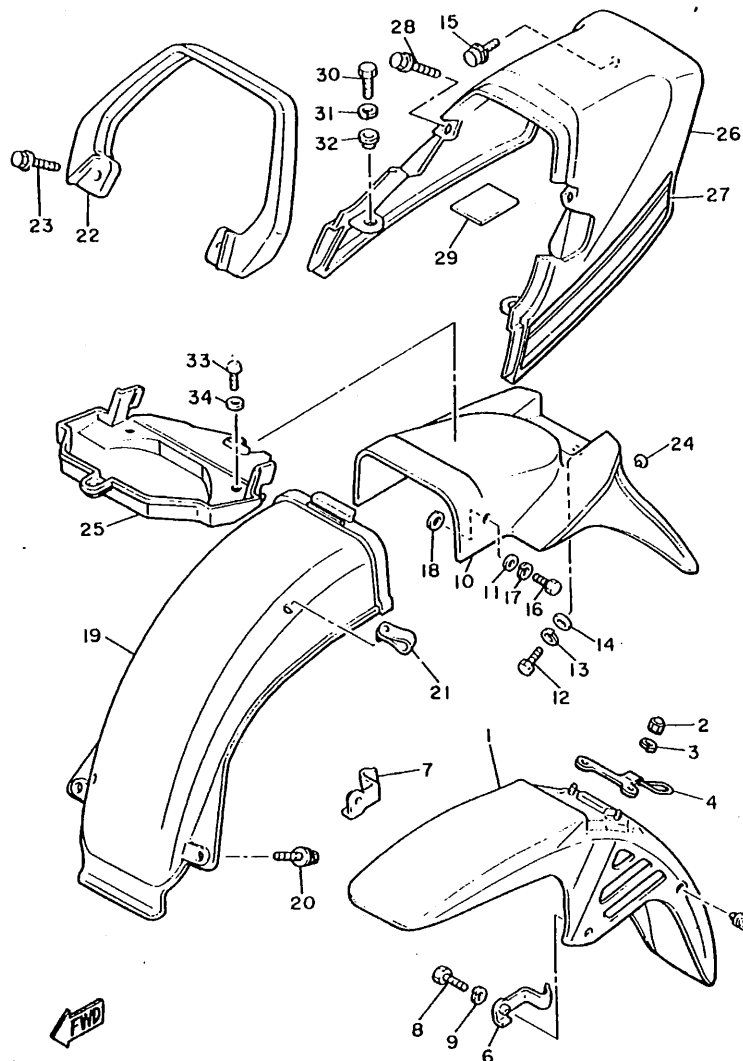

4BB332-1210

REF. NO.	PART NO.	DESCRIPTION	Q'TY	REMARKS
1	31A-21510-00-GE	FRONT FENDER COMP.	1	UR SILKY WHITE
	31A-21510-00-AU	FRONT FENDER COMP.	1	UR VMAX BLUE
2	95303-06800	NUT, crown	2	
3	92990-06100	WASHER, spring	2	
4	3NG-21596-00	HOLDER	1	
5	1A8-21518-00	HOLDER, cable	1	
6	31A-21523-00	PLATE 1	1	
7	31A-21524-00	PLATE 2	1	
8	97313-06016	BOLT	2	
9	92990-06100	WASHER, spring	2	
10	31A-21611-00	FENDER, rear	1	
11	95702-06600	NUT, with washer	2	
12	97011-08016	BOLT	2	
13	92902-08100	WASHER, spring	2	
14	92990-08600	WASHER, plate	2	
15	90119-06108	BOLT, with washer	2	
16	97313-06016	BOLT	2	
17	92990-06100	WASHER, spring	2	
18	92901-06600	WASHER, plate	2	
19	31A-21629-00	GUARD, mud	1	
20	90119-06108	BOLT, with washer	1	
21	90464-12027	CLAMP	1	
22	31A-21645-00	STAY, rear	1	
23	95821-08025	BOLT, flange	2	
24	4G0-21639-00	DAMPER 2	1	
25	31A-21653-00	BOX	1	
26	31A-21651-00-P1	COVER, rear fender	1	UR DARK BLUISH GRAY COCKTAIL
	31A-21651-00-VA	COVER, rear fender	1	UR DYNASTY BLUE

FIG. 21 FENDER

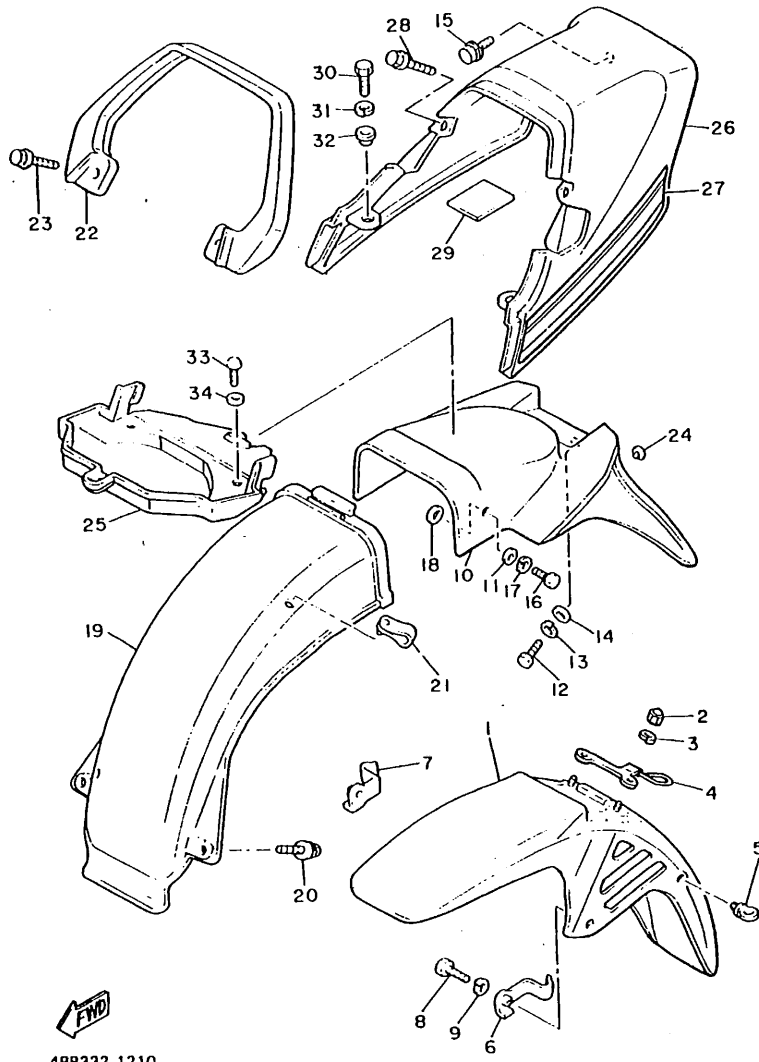

REF. NO.	PART NO.	DESCRIPTION	Q'TY	REMARKS
27	4BB-21660-20	GRAPHIC	1	UR FOR BLUE
	4BB-21660-10	GRAPHIC	1	UR FOR WHITE
28	90119-06044	BOLT, with washer	2	
29	31A-21638-00	DAMPER 1	3	
30	97313-06016	BOLT	2	
31	92990-06100	WASHER, spring	2	
32	90387-06500	COLLAR	2	
33	98506-05010	SCREW, pan head	3	
34	92906-05600	WASHER, plate	3	

48B332-1210

FIG. 22 SIDE COVER

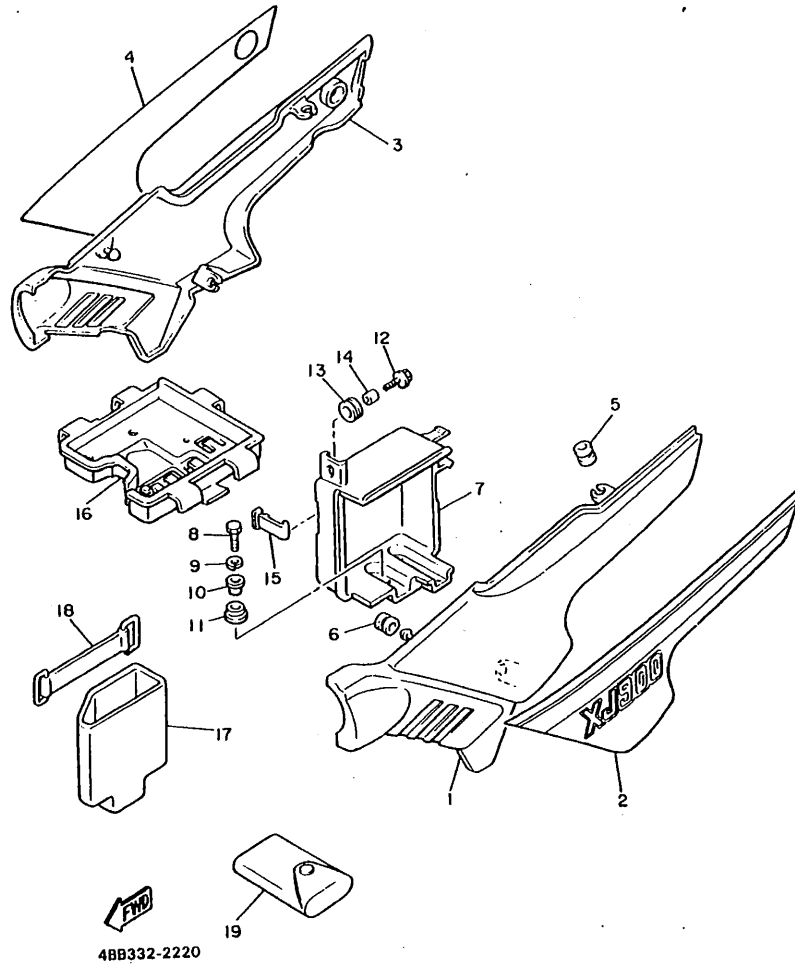

REF. NO.	PART NO.	DESCRIPTION	Q'TY	REMARKS
1	31A-21711-01-7Y	COVER, side 1	1	UR GRAY/BLACK
	31A-21711-01-6Y	COVER, side 1	1	UR DYNASTY BLUE/ BLACK UR FOR BLUE
2	4BB-2173E-20	GRAPHIC 1	1	UR FOR WHITE
	4BB-2173E-10	GRAPHIC 1	1	UR GRAY/BLACK
3	31A-21721-01-7Y	COVER, side 2	1	UR DYNASTY BLUE/ BLACK UR FOR BLUE
	31A-21721-01-6Y	COVER, side 2	1	UR GRAY/BLACK
4	4BB-2173F-20	GRAPHIC SET 1	1	UR FOR WHITE
	4BB-2173F-10	GRAPHIC 2	1	
5	90480-12053	GROMMET	4	
6	90480-01401	GROMMET	2	
7	31A-21240-00	BOX COMP.	1	
8	97011-08025	BOLT	1	
9	92902-08100	WASHER, spring	1	
10	90387-093H1	COLLAR	1	
11	4H7-21746-00	DAMPER	1	
12	90119-06118	BOLT, with washer	1	
13	90480-16233	GROMMET	1	
14	90387-060A7	COLLAR	1	
15	4H7-2175R-00	HOOK, band	1	
16	31A-21170-00	BOX COMP.	1	
17	31A-21245-00	BOX	1	
18	133-82131-00	BAND, battery	1	
19	1FX-28100-00	TOOL KIT	1	

FIG. 23 REAR ARM SUSPENSION

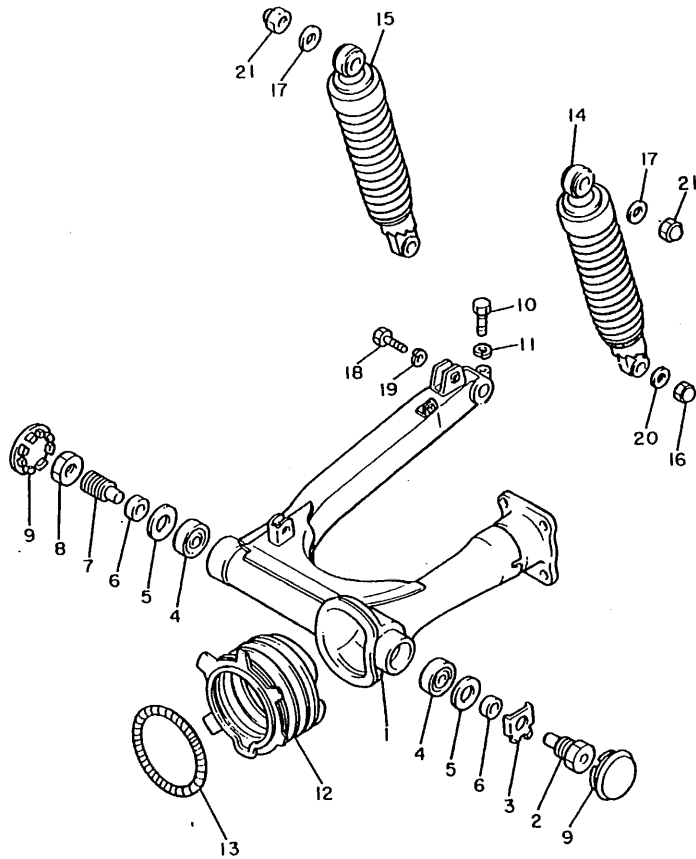

REF. NO.	PART NO.	DESCRIPTION	Q'TY	REMARKS
1	31A-22110-02-35	REAR ARM COMP.	1	SILVER
2	4H7-22141-00	SHAFT, pivot	1	
3	90215-22238	WASHER, lock	1	
4	93332-00010	BEARING	2	
5	93102-25017	OIL SEAL	2	
6	90387-17543	COLLAR	2	
7	1J7-22141-00	SHAFT, pivot	1	
8	1J7-22143-00	NUT	1	
9	5G2-2219X-00	COVER	2	
10	97026-08035	BOLT	1	
11	92906-08100	WASHER, spring	1	
12	4H7-22189-00	BOOT, rubber	1	
13	90506-07136	SPRING, tension	1	
14	3NG-22210-00	SHOCK ABSORBER ASSY, rear	1	
15	3NG-22210-10	SHOCK ABSORBER ASSY, rear	1	
16	90176-10013	NUT, crown	1	
17	90201-10142	WASHER, plate	2	
18	90106-10030	BOLT	1	
19	92990-10100	WASHER, spring	1	
20	90201-10437	WASHER, plate	1	
21	90176-10009	NUT, crown	2	



2HL300-7230

D4

FIG. 24 DRIVE SHAFT

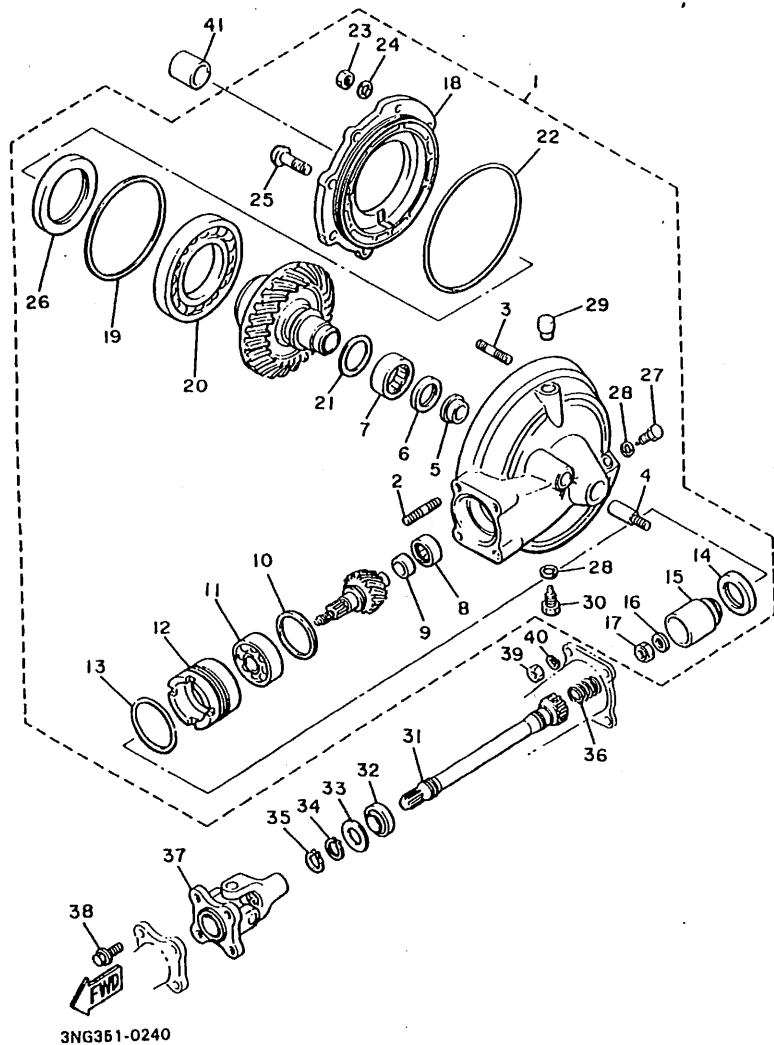

REF. NO.	PART NO.	DESCRIPTION	Q'TY	REMARKS
1	31A-46101-00	REAR AXLE GEAR CASE ASSY	1	
2	90116-10361	.BOLT, stud	4	
3	90116-08360	.BOLT, stud	6	
4	90116-10249	.BOLT, stud	1	
5	4H7-46153-00	.COLLAR, guide	1	
6	93101-30084	.OIL SEAL	1	
7	93311-43710	.BEARING, cylindrical	1	
8	93317-41110	.BEARING, cylindrical	1	
9	2H7-46122-00	.RACE, inner	1	
10	1J7-17537-Y0-15	.SHIM, thrust (0.15T)	1	UR
	1J7-17537-Y0-30	.SHIM, thrust (0.30T)	1	UR
	1J7-17537-Y0-40	.SHIM, thrust (0.40T)	1	UR
	1J7-17537-Y0-50	.SHIM, thrust (0.50T)	1	UR
	1J7-17537-Y0-60	.SHIM, thrust (0.60T)	1	UR
11	93306-30533	.BEARING (B6305RB1 SPECIAL)	1	
12	4H7-46125-00	.RETAINER, bearing	1	
13	93210-60426	.O-RING	1	
14	93101-38098	.OIL SEAL	1	
15	4H7-46123-00	.COUPLING, gear	1	
16	90201-14632	.WASHER, plate	1	
17	90185-14070	.NUT, self-locking	1	
18	4H7-46152-00	.HOUSING, bearing	1	
19	1J7-46117-Y0-25	.SHIM, ring gear (0.25T)	1	UR
	1J7-46117-Y0-30	.SHIM, ring gear (0.30T)	1	UR
	1J7-46117-Y0-40	.SHIM, ring gear (0.40T)	1	UR
	1J7-46117-Y0-45	.SHIM, ring gear (0.45T)	1	UR
	1J7-46117-Y0-50	.SHIM, ring gear (0.50T)	1	UR
20	93316-01403	.BEARING, cylindrical	1	

FIG. 24 DRIVE SHAFT

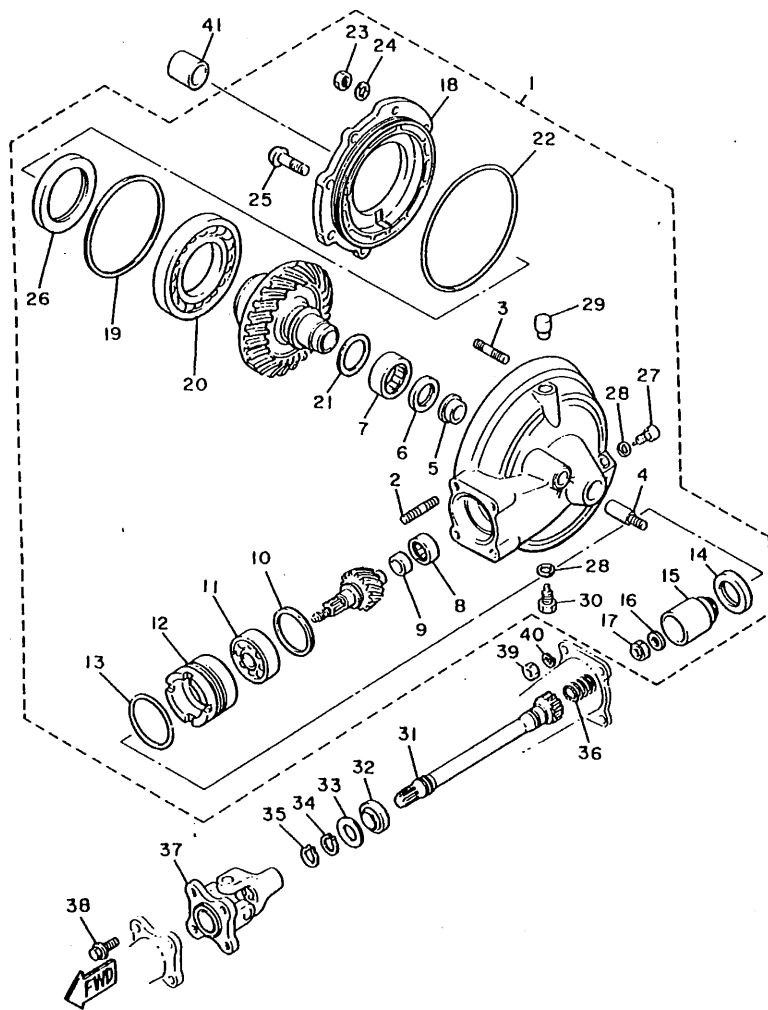

3NG351-0240

REF. NO.	PART NO.	DESCRIPTION	Q'TY	REMARKS
21	22U-46118-00-12	.SHIM, thrust (1.2T)	1	UR
	22U-46118-00-14	.SHIM, thrust (1.4T)	1	UR
	22U-46118-00-16	.SHIM, thrust (1.6T)	1	UR
	22U-46118-00-18	.SHIM, thrust (1.8T)	1	UR
	22U-46118-00-20	.SHIM, thrust (2.0T)	1	UR
22	93211-44348	.O-RING	1	
23	95333-08600	.NUT	6	
24	92901-08700	.WASHER, wave	6	
25	90109-10748	.BOLT	2	
26	93102-70167	.OIL SEAL	1	
27	11H-13455-00	.PLUG	1	
28	214-11198-01	.GASKET	2	
29	2H7-17590-00	.BREATHER COMP.	1	
30	90340-14042	.PLUG, straight screw	1	
31	31A-46172-01	SHAFT, drive	1	
32	93108-23007	OIL SEAL.	1	
33	90201-231A2	WASHER, plate	1	
34	93410-23056	CIRCLIP	1	
35	93410-22039	CIRCLIP	1	
36	90501-16491	SPRING, compression	1	
37	31A-46180-00	CROSS JOINT COMP.	1	
38	90105-08155	BOLT, washer based	4	
39	95336-10600	NUT	4	
40	92906-10100	WASHER, spring	4	
41	90387-172A5	COLLAR	1	

D6

FIG. 25 STEERING

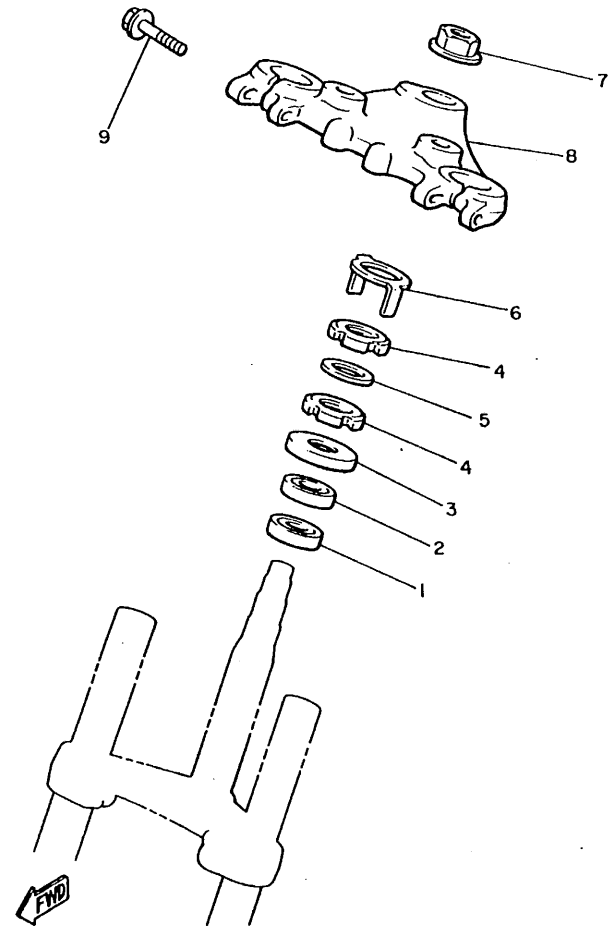

44X171-4250

REF. NO.	PART NO.	DESCRIPTION	Q'TY	REMARKS
1	93332-00008	BEARING	1	
2	93332-00023	BEARING	1	
3	1J7-23415-00	COVER, ball race 1	1	
4	90179-25033	NUT	2	
5	90202-26142	WASHER, plate	1	
6	26H-23418-01	WASHER, special	1	
7	90179-22412	NUT	1	
8	29R-23435-01-98	CROWN, handle	1	LOW GLOSS BLACK
9	95826-08045	BOLT, flange	2	

D7

FIG. 26 FRONT FORK

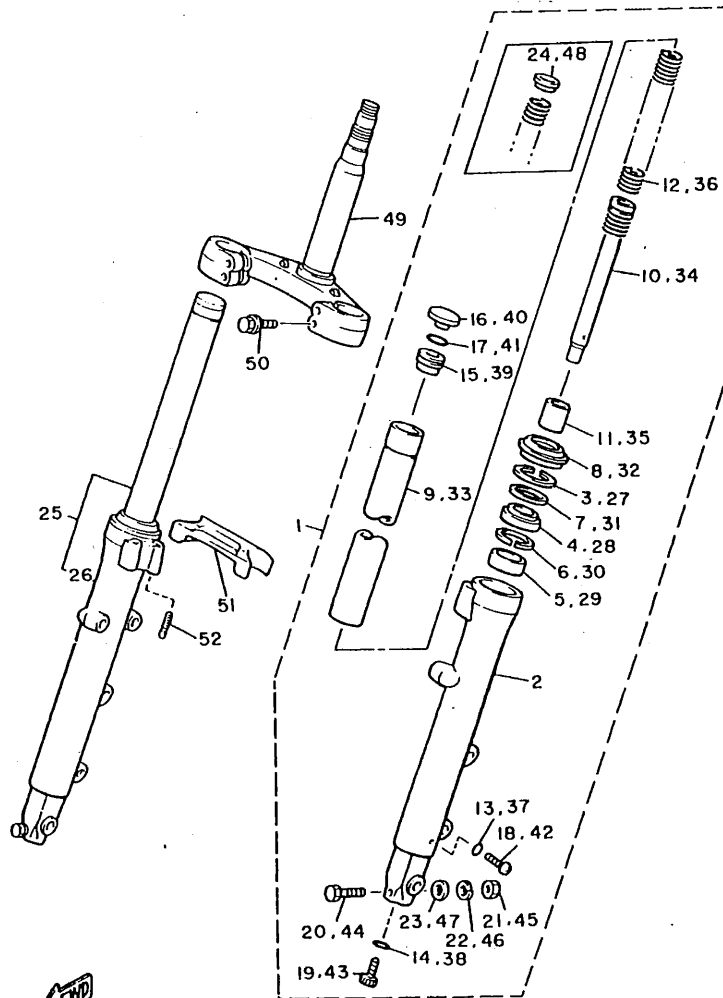

3NG351-0260

REF. NO.	PART NO.	DESCRIPTION	Q'TY	REMARKS
1	1FW-23102-01	FRONT FORK ASSY (L.H)	1	
2	41Y-23126-00	.TUBE, outer 1	1	
3	3R4-23153-00	.RING, snap	1	
4	41Y-23145-00	.OIL SEAL	1	
5	31A-23125-31	.METAL, slide 1	1	
6	31A-23149-31	.WASHER, spring upper	1	
7	41Y-23146-00	.WASHER, oil seal	1	
8	41Y-23144-00	.SEAL, dust	1	
9	1FW-23110-00	.INNER TUBE COMP.1	1	
10	1FW-23170-00	.CYLINDER COMP., front fork	1	
11	5A8-23173-00	.SPINDLE, taper	1	
12	1FW-23141-00	.SPRING, front fork	1	
13	122-23129-00	.GASKET, drain plug	1	
14	509-23158-L0	.GASKET	1	
15	3KM-23111-00	.BOLT, cap	1	
16	26H-23168-00	.CAP, front fork	1	
17	1W1-23114-L0	.GASKET	1	
18	4H7-23119-00	.PLUG, drain	1	
19	278-23181-50	.BOLT, hexagon socket head	1	
20	4U8-23356-10	.BOLT 2	1	
21	95333-08600	.NUT	1	
22	92990-08100	.WASHER, spring	1	
23	92901-08600	.WASHER, plate	2	
24	1W1-23142-L0	.SEAT, spring upper	1	
25	1FW-23103-01	FRONT FORK ASSY (R.H)	1	
26	41Y-23136-00	.TUBE, outer 2	1	
27	3R4-23153-00	.RING, snap	1	
28	41Y-23145-00	.OIL SEAL	1	

FIG. 26 FRONT FORK

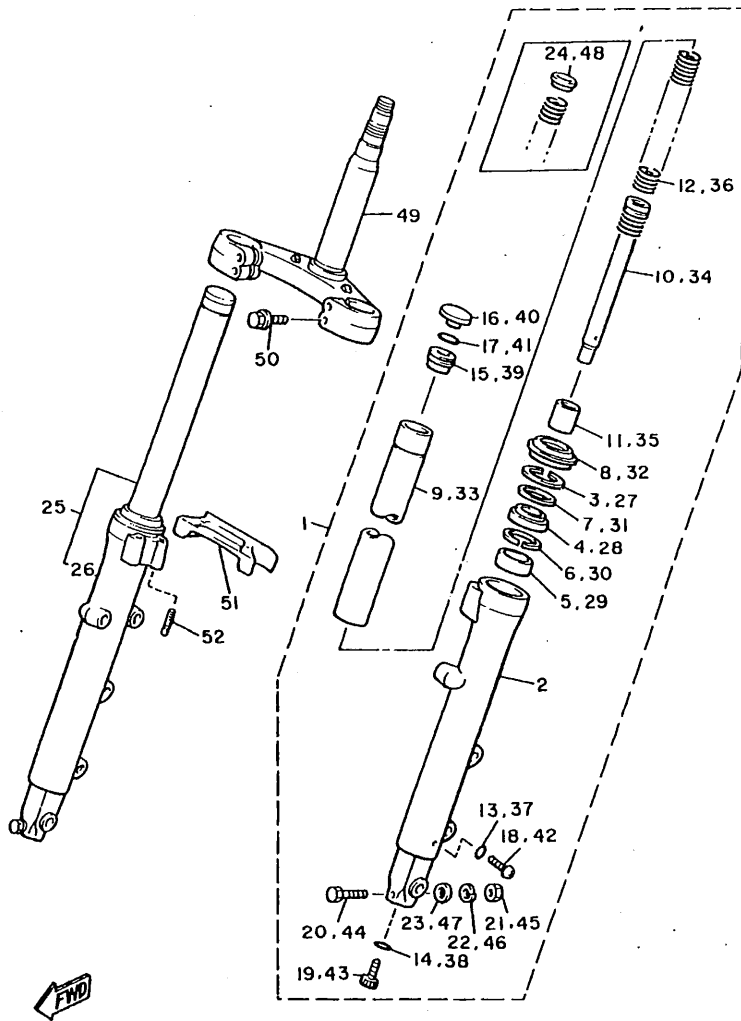

3NG351-0260

REF. NO.	PART NO.	DESCRIPTION	Q'TY	REMARKS
29	31A-23125-31	.METAL, slide 1	1	
30	31A-23149-31	.WASHER, spring upper	1	
31	41Y-23146-00	.WASHER, oil seal	1	
32	41Y-23144-00	.SEAL, dust	1	
33	1FW-23110-00	.INNER TUBE COMP.1	1	
34	1FW-23170-00	.CYLINDER COMP., front fork	1	
35	5A8-23173-00	.SPINDLE, taper	1	
36	1FW-23141-00	.SPRING, front fork	1	
37	122-23129-00	.GASKET, drain plug	1	
38	509-23158-L0	.GASKET	1	
39	3KM-23111-00	.BOLT, cap	1	
40	26H-23168-00	.CAP, front fork	1	
41	1W1-23114-L0	.GASKET	1	
42	4H7-23119-00	.PLUG, drain	1	
43	278-23181-50	.BOLT, hexagon socket head	1	
44	4U8-23356-10	.BOLT 2	1	
45	95333-08600	.NUT	1	
46	92990-08100	.WASHER, spring	1	
47	92901-08600	.WASHER, plate	2	
48	1W1-23142-L0	.SEAT, spring upper	1	
49	1FW-23340-00	UNDER BRACKET COMP.	1	
50	18G-23128-00	BOLT, axle holder	4	
51	31A-2313A-30	BRACE, fork	1	
52	31A-23181-30	BOLT, hexagon socket head	4	

D9

FIG. 27 FUEL TANK

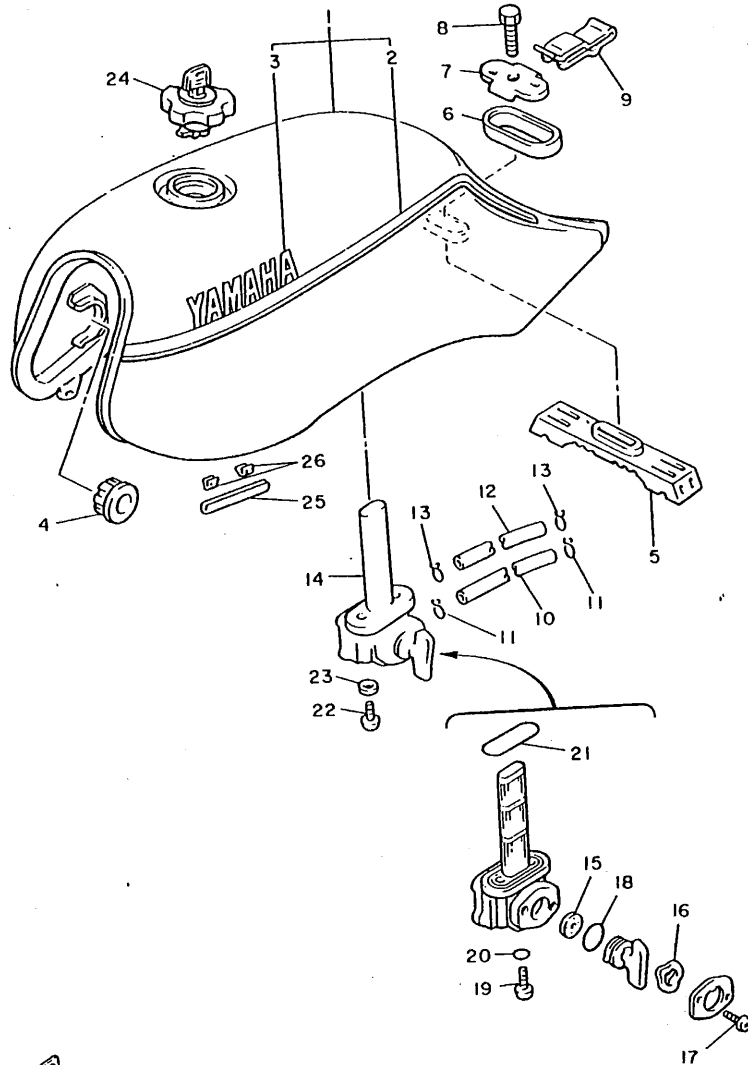

REF. NO.	PART NO.	DESCRIPTION	Q'TY	REMARKS
1	31A-24110-00-W5	FUEL TANK COMP.	1	UR VMAX BLUE/ GRAY
	31A-24110-00-W3	FUEL TANK COMP.	1	UR SILKY WHITE/ DYNASTY BLUE UR FOR BLUE
2	4BB-24240-20	.GRAPHIC SET	1	
	4BB-24240-10	.GRAPHIC SET	1	UR FOR WHITE
3	99246-00045	.EMBLEM, yamaha	2	UR FOR BLUE
	99224-00045	.EMBLEM, yamaha	2	UR FOR WHITE
4	4H7-24181-00	DAMPER, locating 1	2	
5	31A-24182-00	DAMPER, locating 2	1	
6	4K0-24183-00	DAMPER, locating 3	1	
7	4K0-24186-00	WASHER, special	1	
8	90109-08579	BOLT	1	
9	4K0-2411M-00	CLIP	1	
10	90445-11501	HOSE	1	
11	90467-10008	CLIP	2	
12	90445-09500	HOSE	1	
13	90467-08021	CLIP	2	
14	31A-24500-01	FUEL COCK ASSY 1	1	
15	16G-24523-00	.VALVE	1	
16	16G-24518-00	.WASHER, wave	1	
17	98503-03008	.SCREW, pan head	2	
18	2G2-24512-00	.O-RING	1	
19	98580-06008	.SCREW, pan head	1	
20	2G2-24522-00	.GASKET	1	
21	2G2-24534-00	.O-RING	1	
22	90149-06008	SCREW	2	
23	90202-06010	WASHER, plate	2	
24	41Y-24602-01	CAP ASSY	1	
25	31A-24188-00	MOLD, fuel tank	2	



48B351-2270

D10

FIG. 27 FUEL TANK

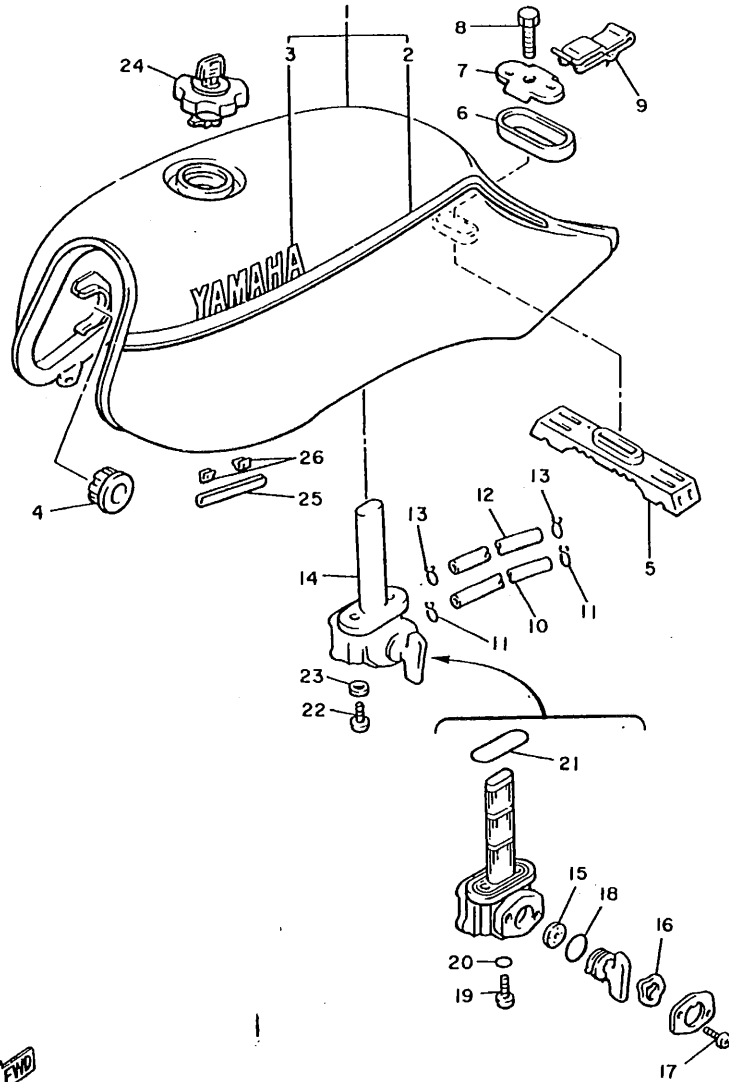

REF. NO.	PART NO.	DESCRIPTION	Q'TY	REMARKS
26	90468-03063	CLIP	4	



488351-2270

D11

FIG. 28 SEAT

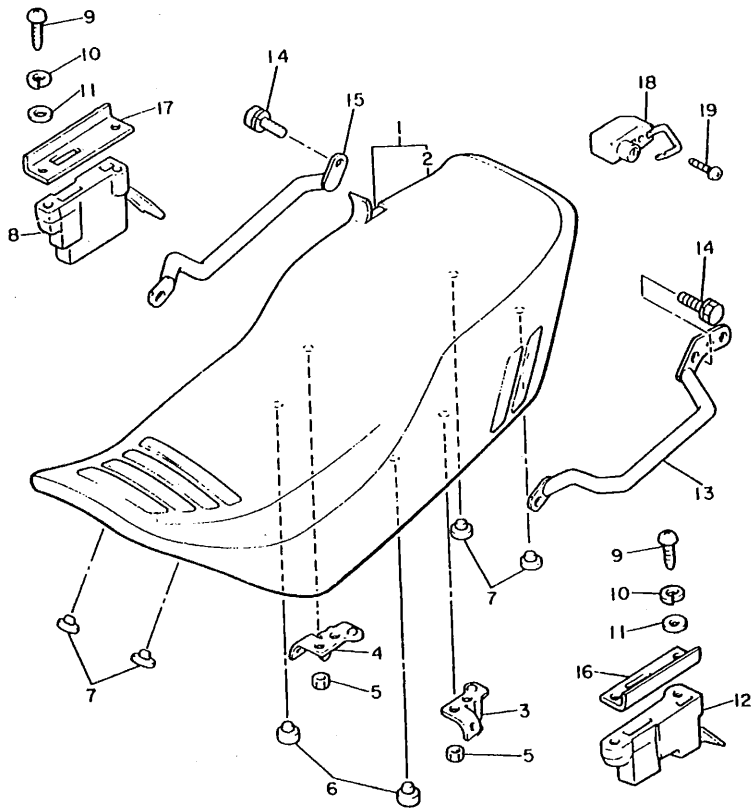

REF. NO.	PART NO.	DESCRIPTION	Q'TY	REMARKS
1	31A-W2472-00	DOUBLE SEAT ASSY	1	BLACK
2	31A-24731-00	.COVER, seat	1	BLACK
3	31A-24728-00	BRACKET, seat	1	
4	31A-24738-00	BRACKET, seat	1	
5	95701-06500	NUT, flange	4	
6	278-27114-A0	STOPPER, main stand	2	
7	509-24724-00	DAMPER, seat	2	
8	41Y-24705-01	SEAT LOCK ASSY	1	
9	98501-06020	SCREW, pan head	4	
10	92990-06100	WASHER, spring	4	
11	92990-06600	WASHER, plate	4	
12	31A-24760-00	SEAT LEVER ASSY	1	
13	31A-21165-00	HANDLE, standing	1	
14	95816-08020	BOLT, flange	2	
15	31A-21275-00	STAY, rear	1	
16	31A-2476A-00	PLATE, guide 1	1	
17	31A-2476E-00	PLATE, guide 2	1	
18	26H-21308-00	HELMET HANGER ASSY	1	
19	90149-06154	SCREW	1	



3NG332-9280

D12

FIG. 29 FRONT WHEEL

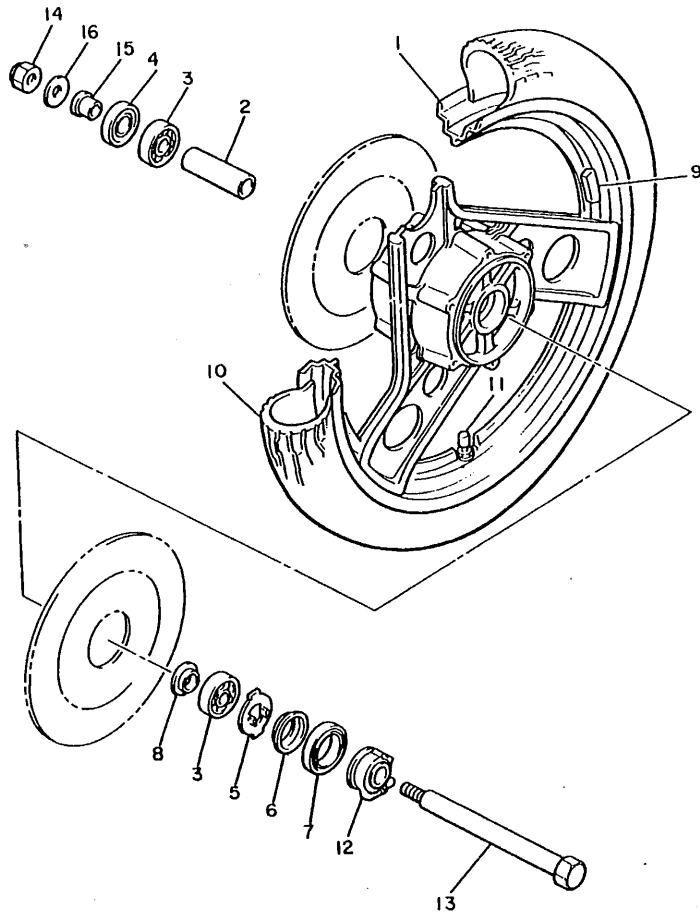

REF. NO.	PART NO.	DESCRIPTION	Q'TY	REMARKS
1	31E-25168-00-WG	CAST WHEEL, front	1	HI TECH SILVER
2	90560-15116	SPACER	1	
3	93306-30203	BEARING (B6302Z)	2	
4	93102-22014	OIL SEAL	1	
5	341-25149-00	CLUTCH, meter	1	
6	341-25846-00	RETAINER, clutch	1	
7	93106-45017	OIL SEAL	1	
8	146-25115-00	FLANGE, spacer 1	1	
9	29L-25398-00	BALANCER, wheel (10G)	1	UR
	29L-25398-10	BALANCER, wheel (20G)	1	UR
	29L-25398-20	BALANCER, wheel (30G)	1	UR
10	*	TIRE (100/90-V18 MT09 MATCH)	1	LM PIRELLI
11	93900-00031	VALVE, rim	1	
12	31A-25190-00	GEAR UNIT ASSY	1	
13	31A-25181-00	AXLE, wheel	1	
14	95601-14100	NUT, u	1	
15	90387-15550	COLLAR	1	
16	92990-14200	WASHER, plain	1	



44X171-4290

FIG. 30 FRONT BRAKE CALIPER

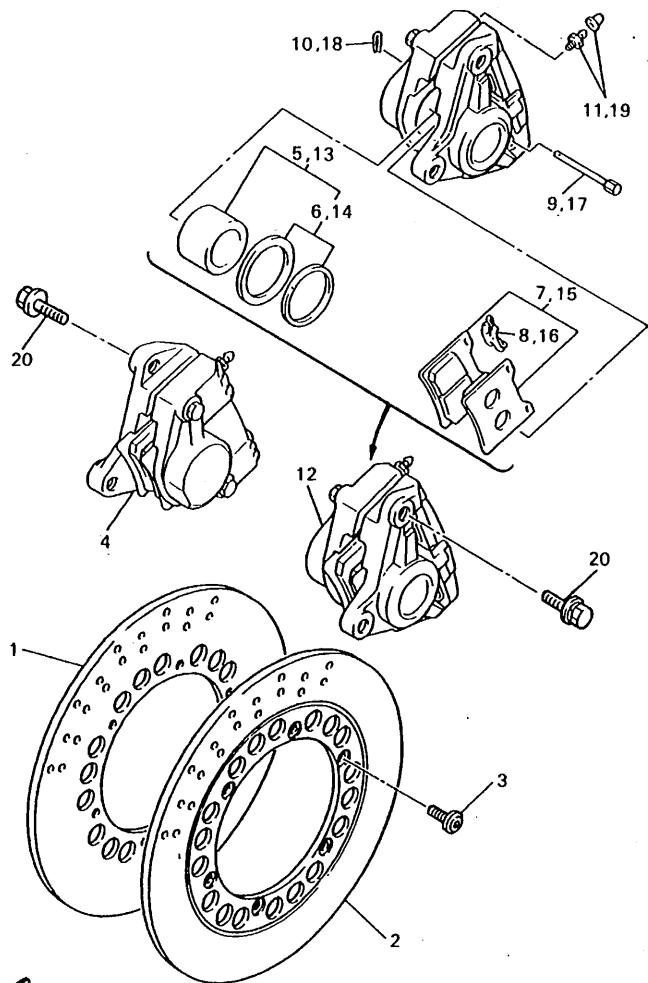

REF. NO.	PART NO.	DESCRIPTION	Q'TY	REMARKS
* 1	2KT-25831-00	DISC, brake (RIGHT)	1	
* 2	2KT-25831-00	DISC, brake (LEFT)	1	
3	90109-08718	BOLT	12	
4	51H-25810-01	CALIPER ASSY (RIGHT)	1	
5	31A-W0057-00	.PISTON ASSY, caliper	1	
6	31A-W0047-00	..CALIPER SEAL KIT	1	
7	26H-W0045-11	.BRAKE PAD KIT	1	
8	29L-25919-00	.SUPPORT, pad	1	
9	1KT-25924-00	.PIN, pad	2	
10	26H-25925-00	.CLIP	2	
11	1J3-W0048-00	.BREED SCREW KIT	1	
12	51H-25810-11	CALIPER ASSY (LEFT)	1	
13	31A-W0057-00	.PISTON ASSY, caliper	1	
14	31A-W0047-00	..CALIPER SEAL KIT	1	
15	26H-W0045-11	.BRAKE PAD KIT	1	
16	29L-25919-00	.SUPPORT, pad	1	
17	1KT-25924-00	.PIN, pad	2	
18	26H-25925-00	.CLIP	2	
19	1J3-W0048-00	.BREED SCREW KIT	1	
20	90105-10308	BOLT, washer based	4	



4BB351-2301

FIG. 31 REAR WHEEL

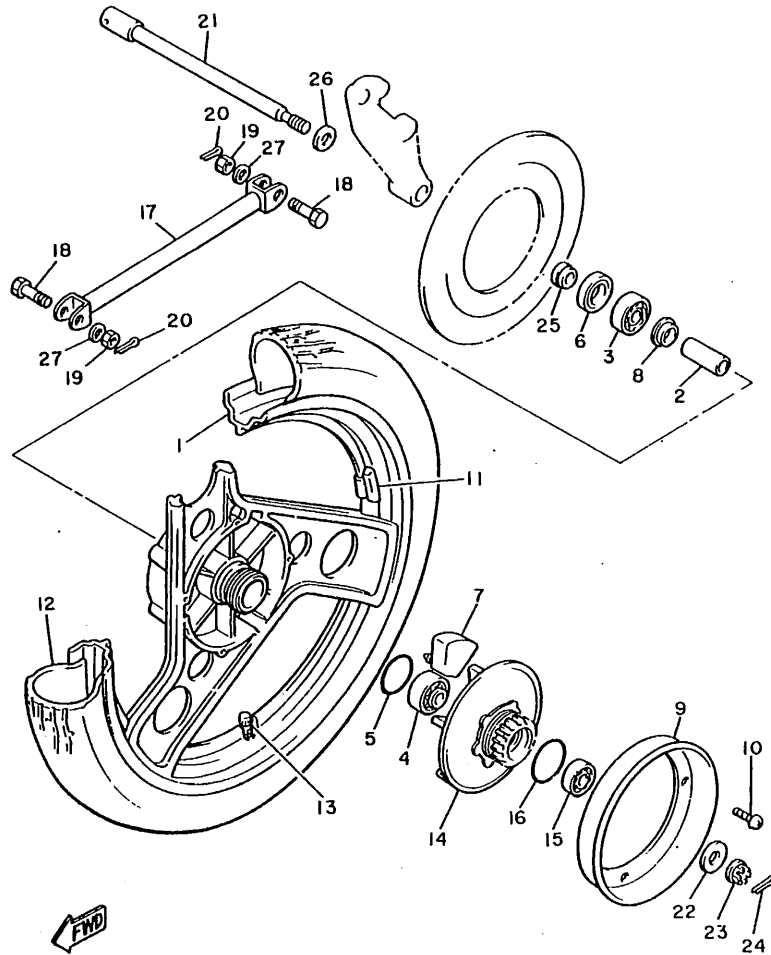

44X171-4310

REF. NO.	PART NO.	DESCRIPTION	QTY	REMARKS
1	31E-25338-20-WG	CAST WHEEL, rear	1	HI TECH SILVER
2	90560-17204	SPACER	1	
3	93306-30306	BEARING (B6303)	1	
4	93302-20306	BEARING	1	
5	93210-48530	O-RING	1	
6	93102-25044	OIL SEAL	1	
7	4G0-25364-00	DAMPER	6	
8	1A1-25115-00	FLANGE, spacer 1	1	
9	31A-25327-00	COVER, plate	1	
10	98501-05010	SCREW, pan head	4	
11	29L-25398-00	BALANCER, wheel (10G)	1	UR
	29L-25398-10	BALANCER, wheel (20G)	1	UR
	29L-25398-20	BALANCER, wheel (30G)	1	UR
12	*	TIRE (120/90-V18 MT09 MATCH)	1	LM PIRELLI
13	93900-00031	VALVE, rim	1	
14	31A-25366-00	CLUTCH, hub	1	
15	93306-20310	BEARING (B6203DU)	1	
16	93210-57428	O-RING	1	
17	31A-25371-00	BAR, tension	1	
18	90102-10056	BOLT, with hole	2	
19	90170-10219	NUT	2	
20	91401-20015	PIN, cotter	2	
21	31A-25381-00	AXLE, wheel	1	
22	90201-144J5	WASHER, plate	1	
23	90179-14217	NUT	1	
24	91401-30030	PIN, cotter	1	
25	90387-170J6	COLLAR	1	
26	56W-25377-00	COLLAR, wheel	1	

FIG. 31 REAR WHEEL

REF. NO.	PART NO.	DESCRIPTION	Q'TY	REMARKS
27	92906-10200	WASHER	2	

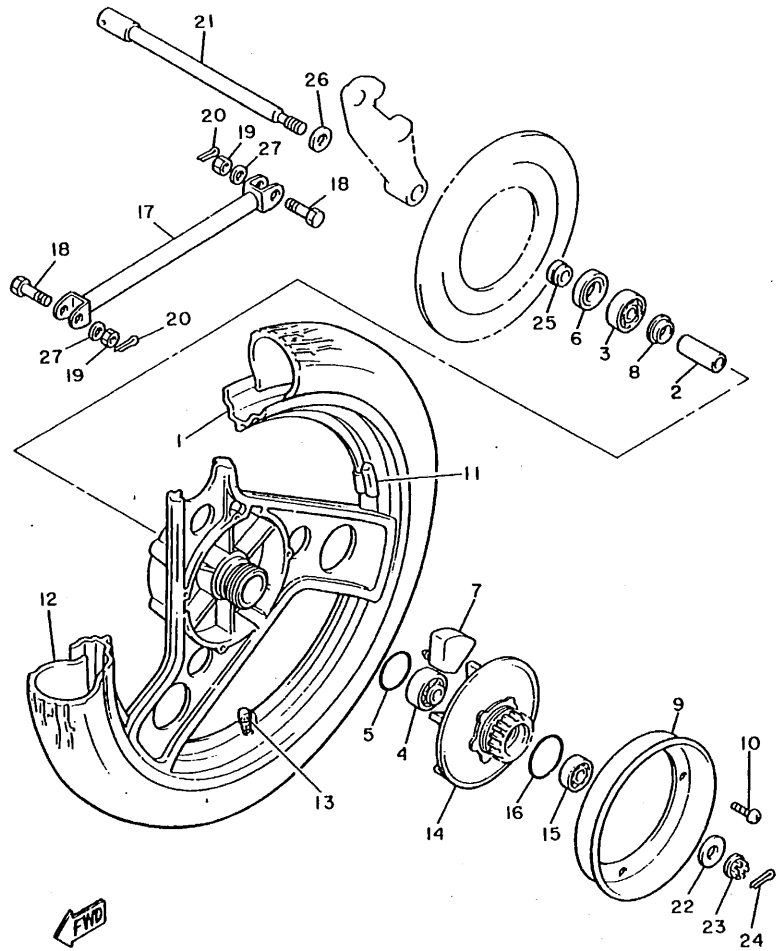

FWD
44X171-4310

FIG. 32 REAR BRAKE CALIPER

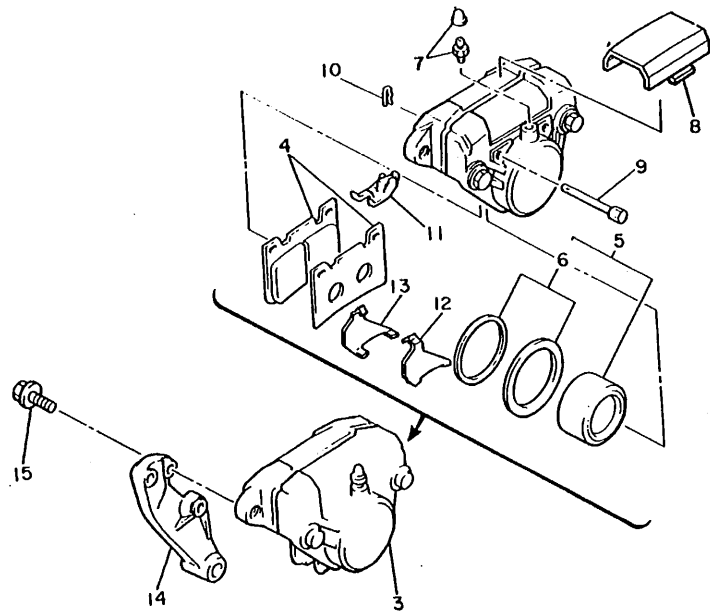

REF. NO.	PART NO.	DESCRIPTION	QTY	REMARKS
1	31A-25831-51	DISC, brake	1	
2	90109-08718	BOLT	6	
3	41Y-25810-52	CALIPER ASSY	1	
4	1FK-W0046-01	.BRAKE PAD KIT, 2	1	
5	31A-W0057-00	.PISTON ASSY, caliper	2	
6	31A-W0047-00	..CALIPER SEAL KIT	1	
7	1J3-W0048-00	.BREED SCREW KIT	2	
8	41Y-25836-00	.COVER, dust	1	
9	1KT-25924-00	.PIN, pad	2	
10	26H-25925-00	.CLIP	2	
11	26H-25919-00	.SUPPORT, pad	1	
12	1FK-25827-00	.SHIM, caliper	1	
13	1FK-25828-00	.SHIM, caliper	1	
14	31A-25819-00	BRACKET, caliper	1	
15	90105-10308	BOLT, washer based	2	



4BB300-2320

FIG. 33 STEERING HANDLE .CABLE

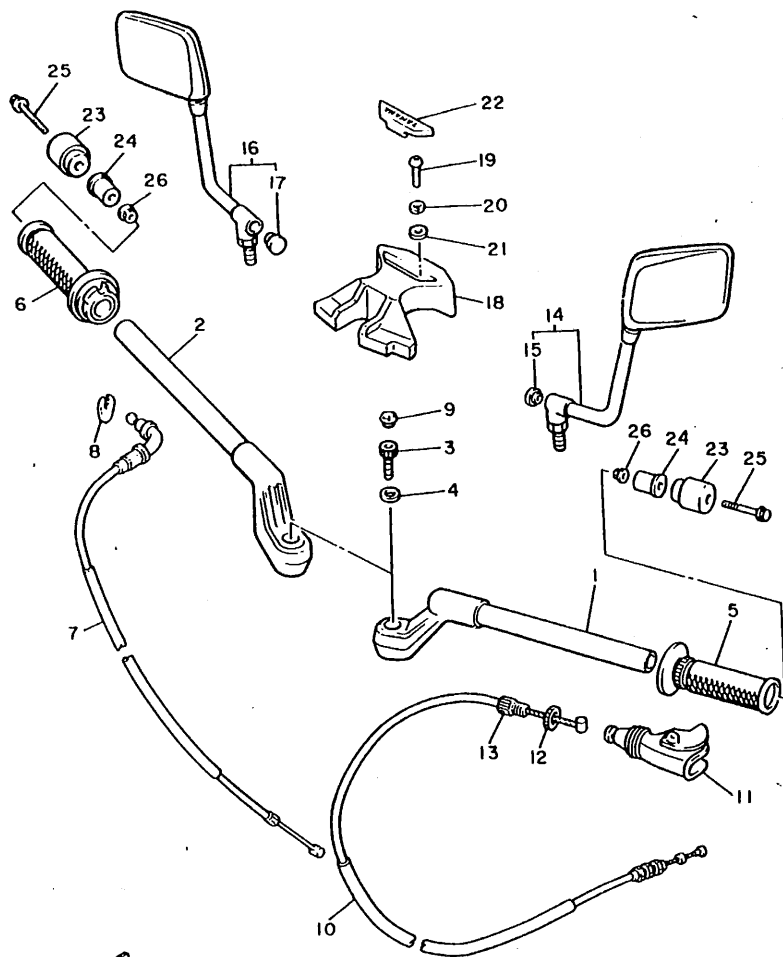

REF. NO.	PART NO.	DESCRIPTION	Q'TY	REMARKS
1	29R-26121-01	HANDLEBAR (LEFT)	1	
2	29R-26122-02	HANDLEBAR (RIGHT)	1	
3	90101-12480	BOLT	2	
4	92990-12200	WASHER, plain	2	
5	31A-26241-00	GRIP (LEFT)	1	
6	31A-26240-00	GRIP ASSY	1	
7	31A-26311-00	CABLE, throttle 1	1	
8	5H0-26393-00	HOLDER	1	
9	31A-23469-02	CAP, bolt	2	
10	31A-26335-01	CABLE, clutch	1	
11	31A-26372-00	COVER, handle lever 1	1	
12	90179-08148	NUT	1	
13	90123-08046	BOLT	1	
14	36Y-26290-G0	BACK MIRROR ASSY (LEFT)	1	
15	36Y-26133-00	.CAP	1	
16	36Y-26290-T0	BACK MIRROR ASSY (RIGHT)	1	
17	36Y-26133-00	.CAP	1	
18	31A-26213-00	COVER, upper	1	
19	92516-06030	SCREW, pan head	2	
20	92906-06100	WASHER, spring	2	
21	92906-06600	WASHER, plate	2	
22	31A-26216-00	CAP, handlebar cover	1	
23	58L-26246-00	END, grip	2	
24	58L-2622F-00	DAMPER, locating 1	2	
25	91311-06080	BOLT	2	
26	90179-06403	NUT	2	

3NG351-0330

FIG. 34 FRONT MASTER CYLINDER

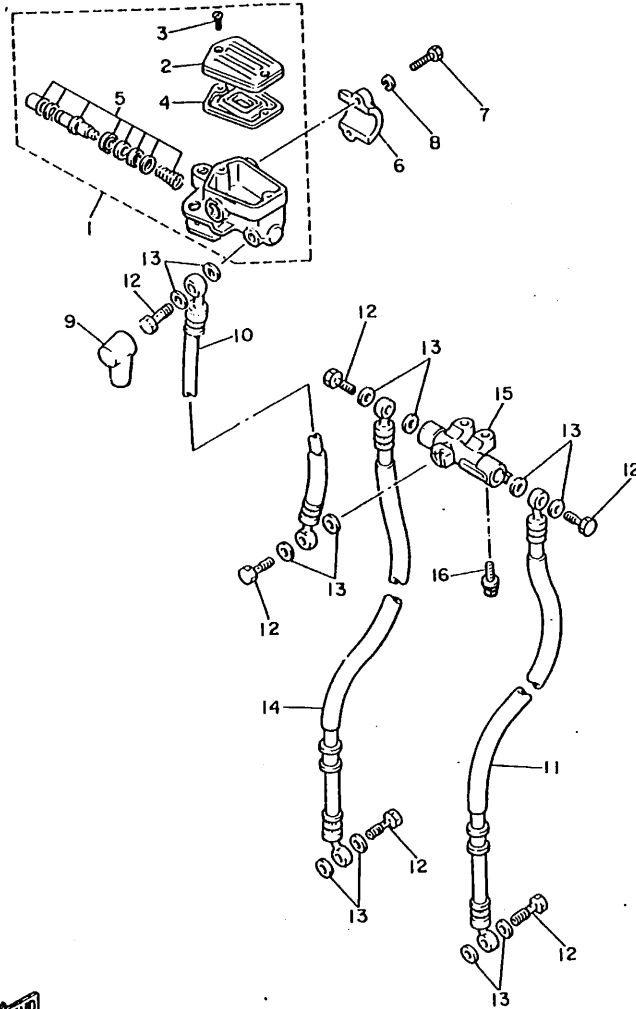

REF. NO.	PART NO.	DESCRIPTION	Q'TY	REMARKS
1	36Y-25850-01	MASTER CYLINDER ASSY	1	
2	36Y-25852-01	.CAP, reservoir	1	
3	98706-04012	.SCREW, flat head	2	
4	36Y-25854-00	.DIAPHRAGM, reservoir	1	
5	36Y-W0041-00	.CYLINDER KIT, master	1	
6	36Y-25867-00	BRACKET, master cylinder	1	
7	91316-06025	BOLT	2	
8	92906-06100	WASHER, spring	2	
9	4L0-25862-00	BOOT, master cylinder	1	
10	4K0-25872-00	HOSE, brake 1	1	
11	31A-25873-02	HOSE, brake 2	1	
12	90401-10096	BOLT, union	6	
13	90201-10118	WASHER, plate	12	
14	31A-25873-12	HOSE, brake 2	1	
15	1FW-25885-00	JOINT	1	
16	91316-06025	BOLT	2	



3NG332-9340

FIG. 35 STAND • FOOTREST

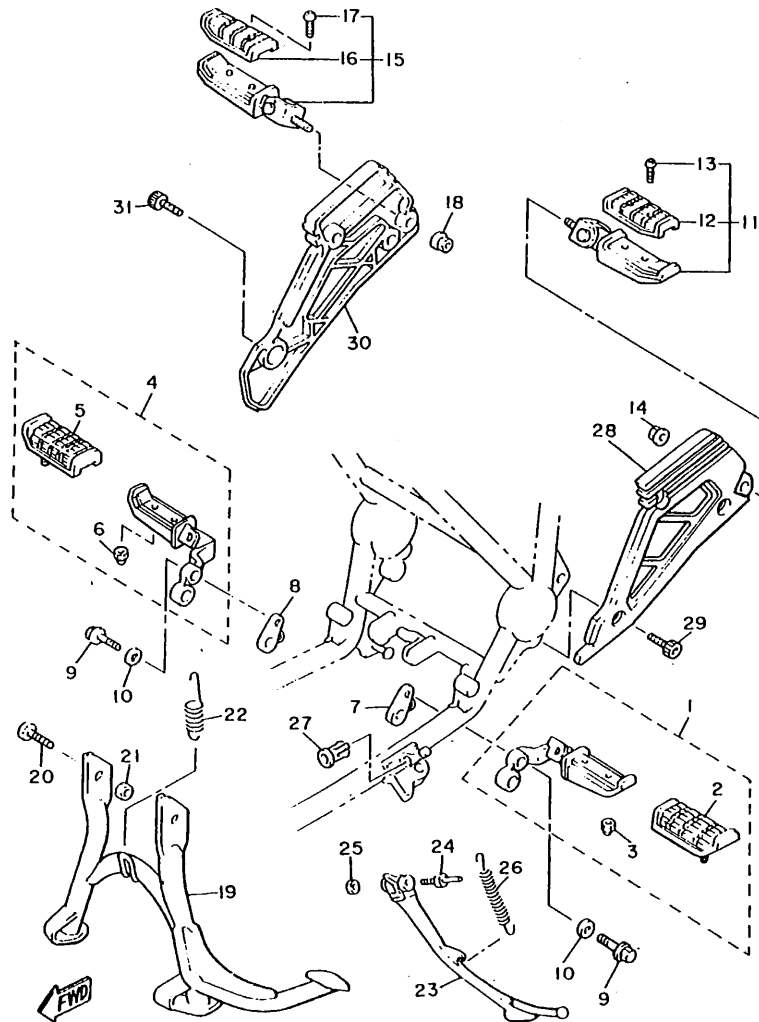

2HL300-7350

REF. NO.	PART NO.	DESCRIPTION	Q'TY	REMARKS
1	41Y-27410-00	FRONT FOOTREST ASSY (LEFT)	1	
2	22N-27413-00	.COVER, footrest	1	
3	95601-06100	.NUT, u	2	
4	41Y-27420-00	FRONT FOOTREST ASSY (RIGHT)	1	
5	22N-27413-00	.COVER, footrest	1	
6	95601-06100	.NUT, u	2	
7	31A-27412-01	BRACKET, footrest 1	1	
8	31A-27422-01	BRACKET, footrest 2	1	
9	95811-10035	BOLT, flange	2	
10	90201-105A2	WASHER, plate	2	
11	29L-27430-00	REAR FOOTREST ASSY 1	1	
12	22N-27433-00	.COVER, rear footrest	1	
13	98506-05010	.SCREW, pan head	2	
14	95701-10500	NUT, flange	1	
15	29L-27440-00	REAR FOOTREST ASSY 2	1	
16	22N-27433-00	.COVER, rear footrest	1	
17	98506-05010	.SCREW, pan head	2	
18	95701-10500	NUT, flange	1	
19	31A-27111-00-R4	STAND, main	1	BLACK (FOR ELECTRODEPOSIT)
20	90109-10606	BOLT	2	
21	90185-10060	NUT, self-locking	2	
22	90506-40348	SPRING, tension	1	
23	31E-27311-00-R4	STAND, side	1	BLACK (FOR ELECTRODEPOSIT)
24	90109-10590	BOLT	1	
25	90185-10037	NUT, self-locking	1	
26	90507-29033	SPRING, tension	1	
27	5G2-27351-00	GUIDE, side stand	1	
28	31A-27442-00	BRACKET 2	1	

FIG. 35 STAND • FOOTREST

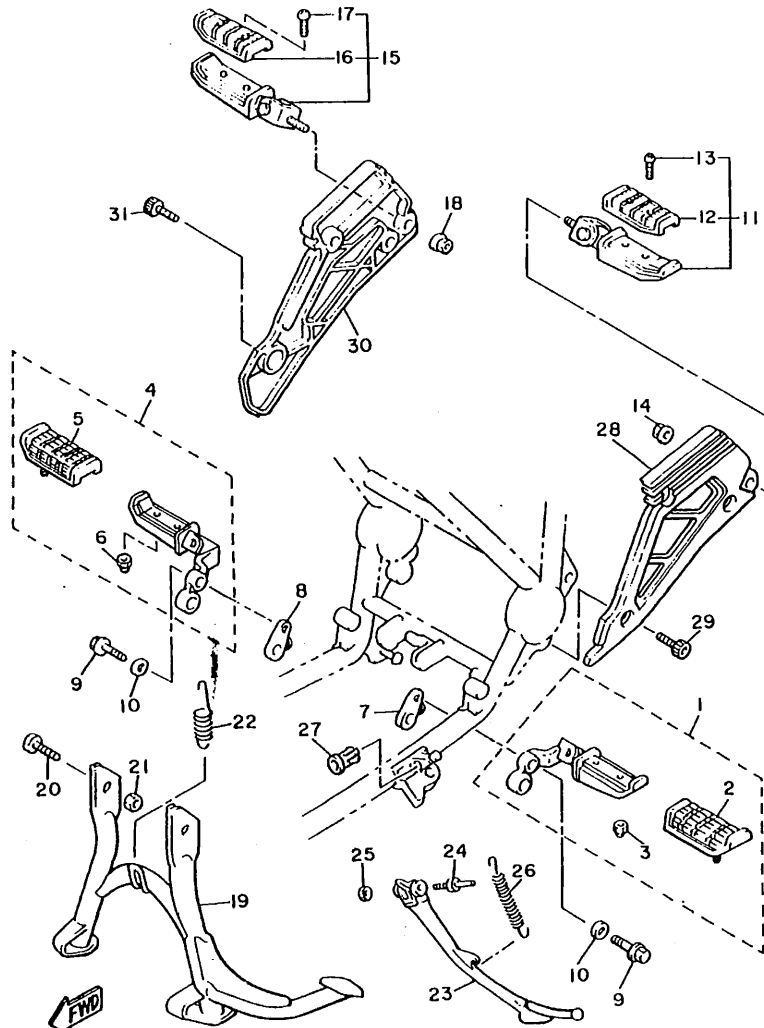

2HL300-7350

REF. NO.	PART NO.	DESCRIPTION	Q'TY	REMARKS
29	91311-10025	BOLT	2	
30	31A-27443-00	BRACKET 3	1	
31	91311-10020	BOLT	2	

FIG. 36 REAR MASTER CYLINDER

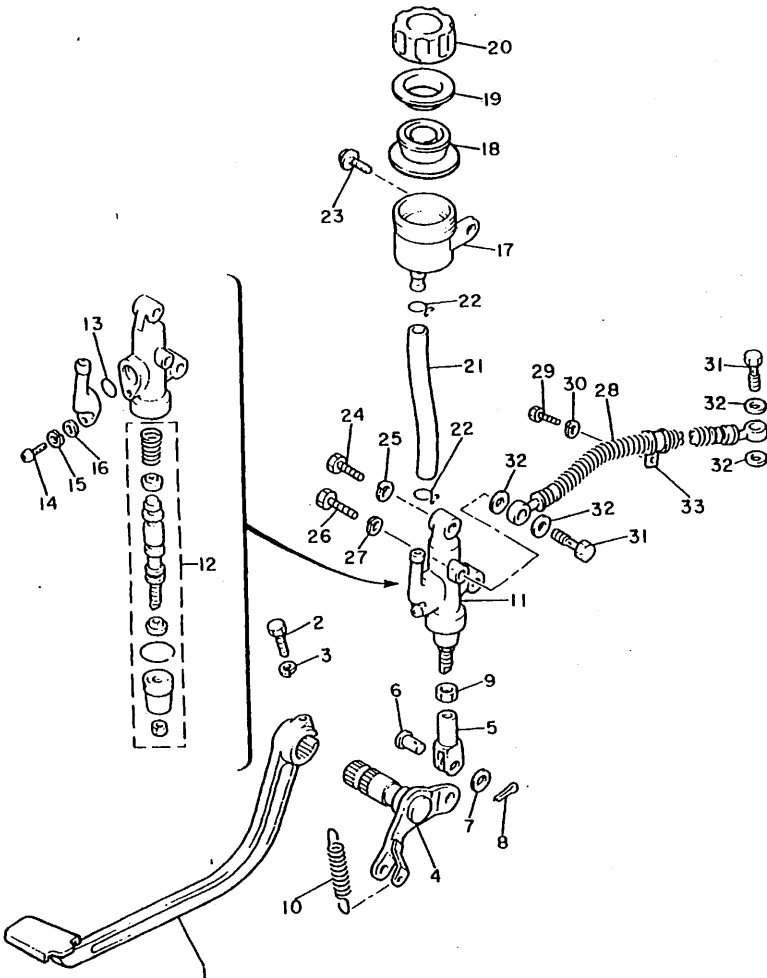

REF. NO.	PART NO.	DESCRIPTION	Q'TY	REMARKS
1	41Y-27211-00	PEDAL, brake	1	
2	90109-06468	BOLT	1	
3	92990-06100	WASHER, spring	1	
4	31A-27212-00	SHAFT, brake pedal	1	
5	31A-27222-00	JOINT	1	
6	90240-08013	PIN, clevis	1	
7	90201-08083	WASHER, plate	1	
8	91401-20015	PIN, cotter	1	
9	95303-08700	NUT	1	
10	90506-20249	SPRING, tension	1	
11	31A-25850-50	MASTER CYLINDER ASSY	1	
12	31A-W0042-50	.CYLINDER KIT, master	1	
13	93210-15620	.O-RING	1	
14	98506-04012	.SCREW, pan head	1	
15	92906-04100	.WASHER, spring	1	
16	92906-04600	.WASHER; plate	1	
17	31A-25894-01	TANK, reservoir	1	
18	360-25854-00	DIAPHRAGM, reservoir	1	
19	2GU-25855-00	BUSH, diaphragm	1	
20	2KF-25852-50	CAP, reservoir	1	
21	31A-25895-00	HOSE, reservoir	1	
22	90601-11525	NYLON CLIP 1	2	
23	90159-06056	SCREW, with washer	1	
24	97016-08025	BOLT	1	
25	92906-08100	WASHER, spring	1	
26	97026-08035	BOLT	1	
27	92906-08100	WASHER, spring	1	
28	31A-25872-51	HOSE, brake 1	1	

FWD
3NG332-9360

FIG. 36 REAR MASTER CYLINDER

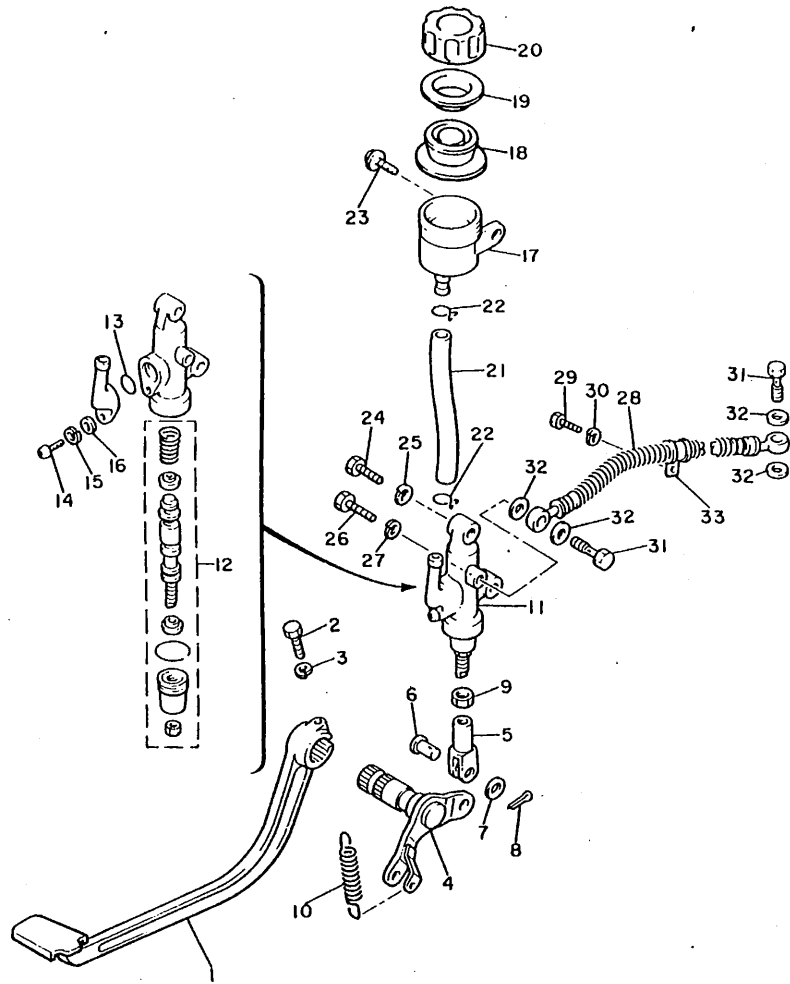

REF. NO.	PART NO.	DESCRIPTION	Q'TY	REMARKS
29	97026-06012	BOLT	1	
30	92906-06100	WASHER, spring	1	
31	90401-10096	BOLT, union	2	
32	90201-10118	WASHER, plate	4	
33	90461-08031	CLAMP	1	



3NG332-9380

FIG. 37 COWLING 1

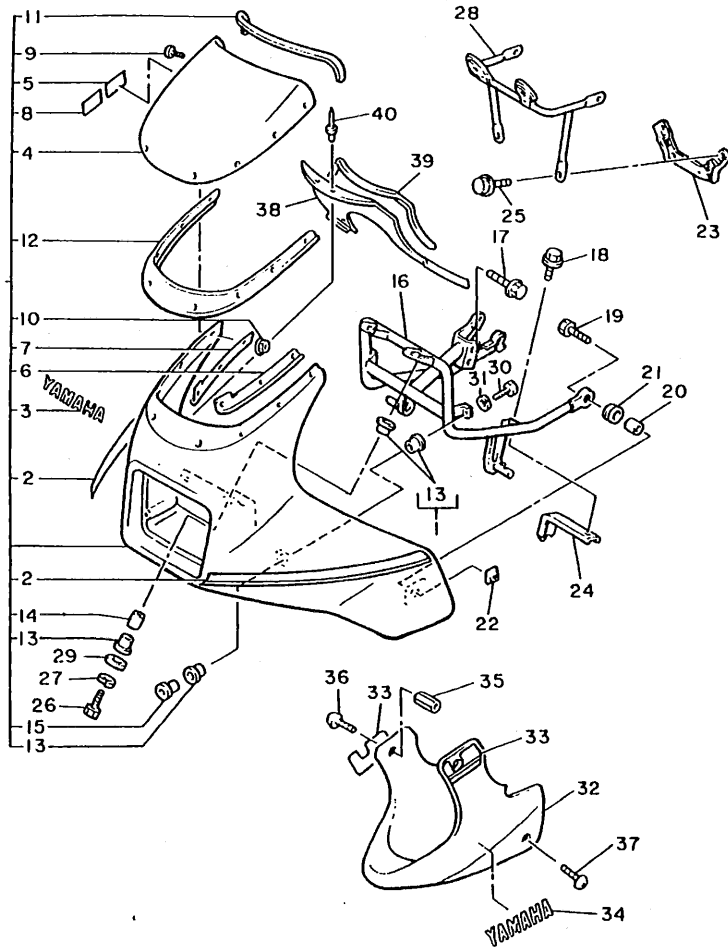

REF. NO.	PART NO.	DESCRIPTION	Q'TY	REMARKS
1	53U-Y2835-90-5Y	COWLING ASS'Y	1	UR VMAX BLUE/ GRAY
	53U-Y2835-70-4Y	COWLING ASS'Y	1	UR SILKY WHITE/ DYNASTY BLUE UR FOR BLUE
2	4BB-28390-20	.GRAPHIC SET, cowling	1	UR FOR WHITE
	4BB-28390-10	.GRAPHIC SET, cowling	1	UR FOR BLUE
3	99236-00020	.EMBLEM, yamaha	1	UR FOR WHITE
	99234-00020	.EMBLEM, yamaha	1	UR FOR BLUE
4	2HL-28381-00	.WINDSHIELD	1	
5	3JJ-2835Y-00	.LABEL, caution	1	ENGLISH
6	42N-28335-00	.PLATE	1	
7	42N-28336-00	.PLATE	1	
8	3JJ-2835Y-10	.LABEL, caution	1	FRENCH
9	90150-05023	.SCREW, round head	8	
10	95706-05500	.NUT, flange	8	
11	42N-28376-00	.TRIM	1	
12	31A-28345-00	.MOLE 1	1	
13	90480-22362	.GROMMET	8	
14	90560-08237	.SPACER	2	
15	90387-050J5	.COLLAR	2	
16	42N-28356-00	STAY 1	1	
17	95816-08012	BOLT, flange	3	
18	90119-06108	BOLT, with washer	2	
19	98006-06020	BOLT	2	
20	90387-067K8	COLLAR	2	
21	90480-18276	GROMMET	2	
22	42N-28317-00	NUT, emblem	2	
23	42N-28357-00	STAY 2	1	
24	42N-2831U-00	STAY, side 1	2	
25	95826-06010	BOLT, flange	2	



4BB332-2370

FIG. 37 COWLING 1

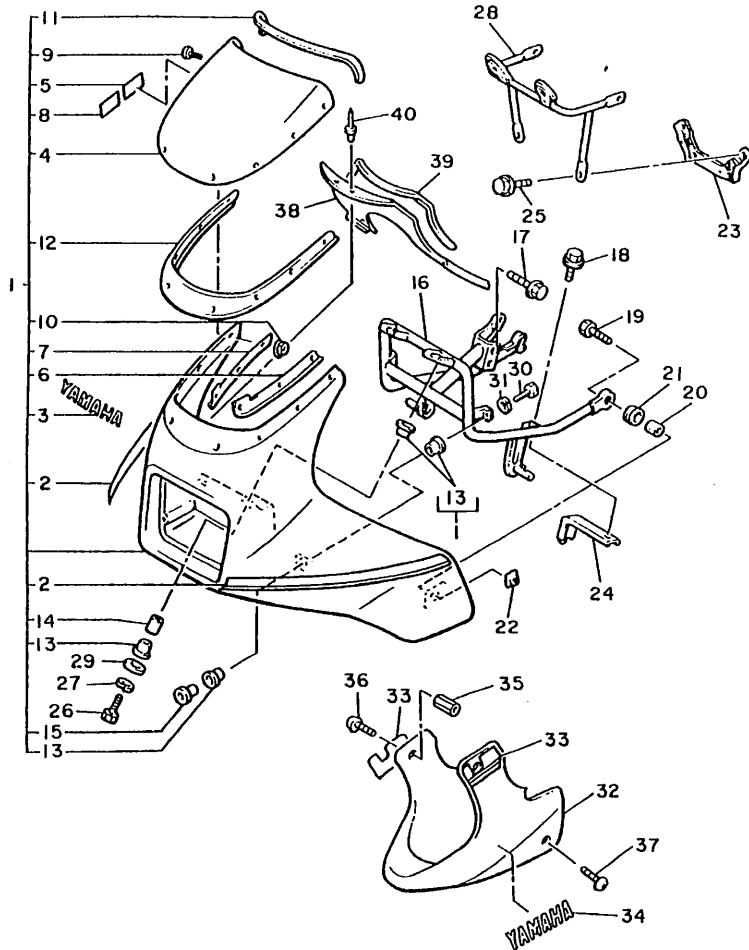

REF. NO.	PART NO.	DESCRIPTION	Q'TY	REMARKS
26	97006-06035	BOLT	2	
27	92906-06100	WASHER, spring	2	
28	42N-28358-00	STAY 3	1	
29	90201-06074	WASHER, plate	2	
30	97016-06016	BOLT	2	
31	92906-06100	WASHER, spring	2	
32	42N-28385-00-GE	COVER, lower	1	UR SILKY WHITE
	42N-28385-00-AU	COVER, lower	1	UR VMAX BLUE/ GRAY
33	4BB-28301-20	GRAPHIC SET, lower cover 1	1	UR FOR BLUE
	4BB-28301-10	GRAPHIC SET, lower cover 1	1	UR FOR WHITE
34	99236-00055	EMBLEM, yamaha	2	UR FOR BLUE
	99234-00055	EMBLEM, yamaha	2	UR FOR WHITE
35	42N-2834K-00	BOSS	2	
36	90154-05001	SCREW, binding	2	
37	90154-06014	SCREW, binding	2	
38	53U-2836K-01	PANEL, inner 1	1	
39	53U-28376-00	TRIM	1	
40	90269-05039	RIVET	4	



4BB332-2370

E11

FIG. 38 GENERATOR

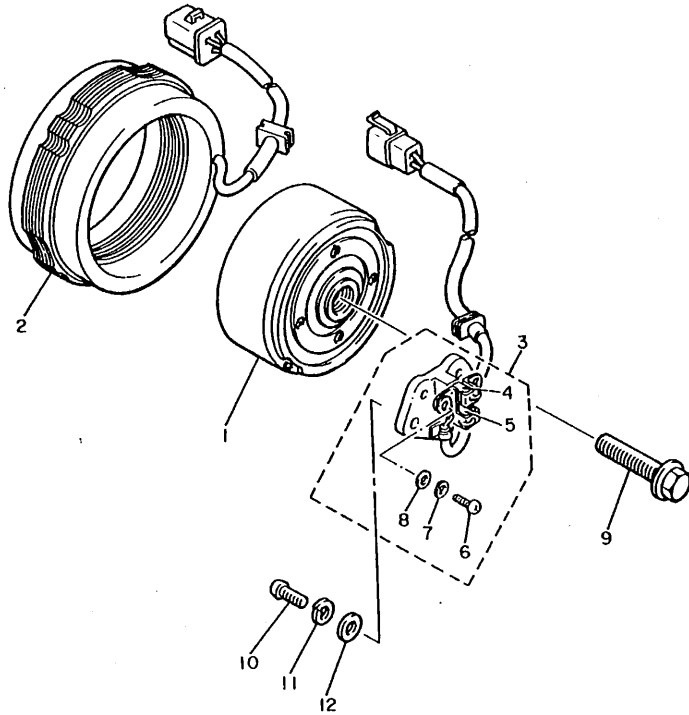

REF. NO.	PART NO.	DESCRIPTION	Q'TY	REMARKS
1	4H7-81650-10	ROTOR ASSY	1	
2	4H7-81610-10	STATOR ASSY	1	
3	4H7-81619-10	BRUSH HOLDER ASSY	1	
4	46X-81611-10	.BRUSH 1	1	
5	4G0-81612-10	.BRUSH 2	1	
6	98511-04012	.SCREW, pan head	2	
7	92901-04100	.WASHER, spring	2	
8	92901-04600	.WASHER, plate	2	
9	90105-10152	BOLT, washer based	1	
10	98502-06016	SCREW, pan head	2	
11	92990-06100	WASHER, spring	2	
12	92990-06600	WASHER, plate	2	



22N010-3130

E12

FIG. 39 PICK UP COIL . GOVERNOR

REF. NO.	PART NO.	DESCRIPTION	Q'TY	REMARKS
1	1NW-81673-11	ROTOR	1	
2	31A-81671-10	BASE, pick up	1	
3	91316-08030	BOLT	1	
4	90159-06107	SCREW, with washer	2	
5	93604-08071	PIN, dowel	1	
6	90465-08277	CLAMP	1	
7	90465-08156	CLAMP	1	
8	90465-12160	CLAMP	1	

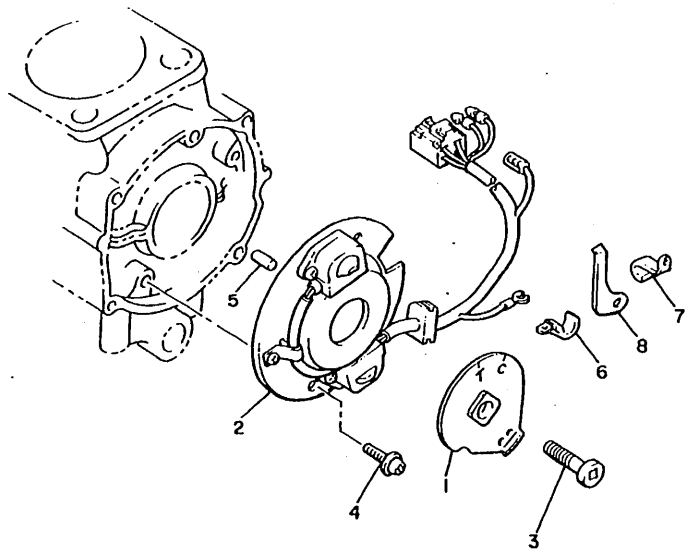

1FW332-6380

FIG. 40 STARTING MOTOR

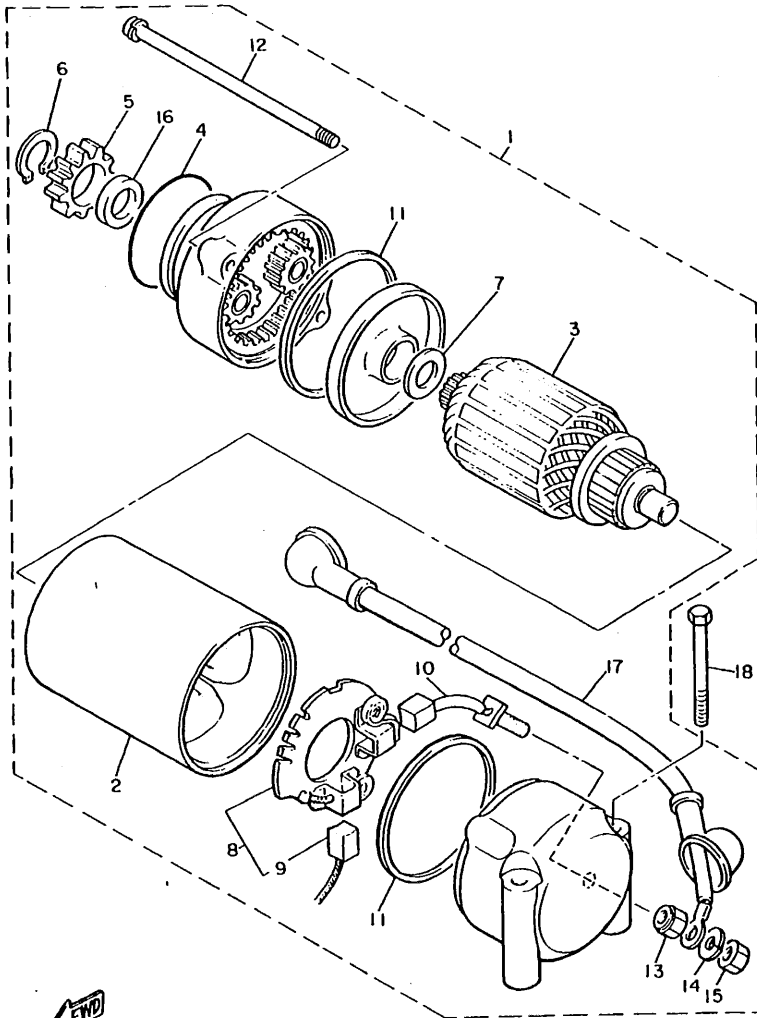

REF. NO.	PART NO.	DESCRIPTION	Q'TY	REMARKS
1	4H7-81800-50	STARTING MOTOR ASSY	1	
2	4H7-81810-01	.STATOR ASSY	1	
3	4H7-81850-00	.ARMATURE ASSY	1	
4	4H7-81847-01	.O-RING	1	
5	4H7-15511-01	.GEAR, starting motor	1	
6	4H7-81819-00	.CIRCLIP	1	
7	4H7-81843-50	.WASHER 1	1	
8	4H7-81840-01	.BRUSH HOLDER ASSY	1	
9	4H7-81811-00	..BRUSH 1	1	
10	4H7-81812-01	.BRUSH 2	1	
11	4H7-81844-00	.GASKET	2	
12	4H7-81826-01	.BOLT	2	
13	4H7-81872-00	.NUT, special	1	
14	92990-06100	.WASHER, spring	1	
15	95303-06600	.NUT	1	
16	4H7-81834-00	.RING	1	
17	4BB-81815-00	.LEAD WIRE ASSY	1	
18	95801-06060	BOLT, flange	1	



4BB332-1400

FIG. 41 FLASHER LIGHT

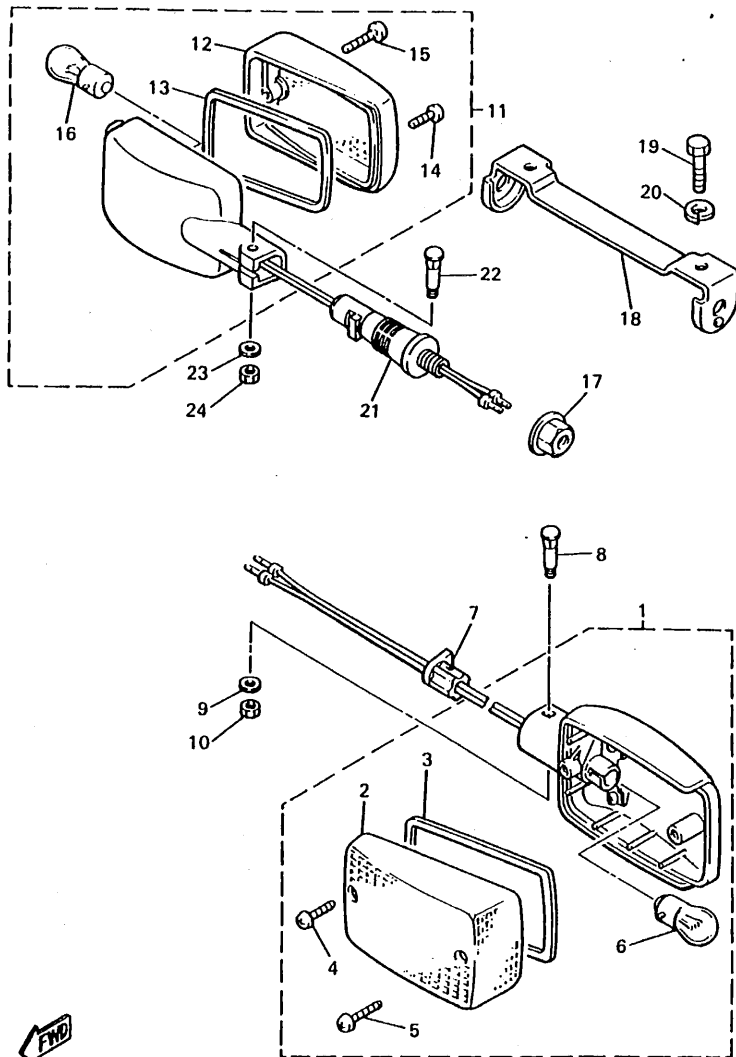

REF. NO.	PART NO.	DESCRIPTION	Q'TY	REMARKS
1	31A-83301-40	FRONT FLASHER LIGHT ASSY 1	2	
2	5G2-83312-00	.LENS, flasher	1	
3	5G2-83313-00	.GASKET, flasher lens	1	
4	98511-04016	.SCREW, pan head	1	
5	97701-40535	.SCREW, tapping	1	
* 6	306-83311-40	.BULB, flasher (12V-21W)	1	
7	4L0-83321-00	DAMPER, flasher 1	2	
8	4G0-83317-00	BOLT, flasher 1	2	
9	92990-05600	WASHER, plate	2	
10	95303-05600	NUT	2	
11	31A-83303-40	REAR FLASHER LIGHT ASSY 1	2	
12	11M-83312-00	.LENS, flasher	1	
13	5G2-83313-00	.GASKET, flasher lens	1	
14	98511-04016	.SCREW, pan head	1	
15	97701-40535	.SCREW, tapping	1	
* 16	306-83311-40	.BULB, flasher (12V-21W)	1	
17	95701-12500	NUT, flange	2	
18	4V8-83318-00	STAY, flasher 1	1	
19	97026-06010	BOLT	2	
20	92906-06100	WASHER, spring	2	
* 21	4G0-83318-00	STAY, flasher 1	2	
* 22	4G0-83317-00	BOLT, flasher 1	2	
* 23	92990-05600	WASHER, plate	2	
* 24	95303-05600	NUT	2	



4BB351-2411

FIG. 42 METER

REF. NO.	PART NO.	DESCRIPTION	Q'TY	REMARKS
1	41Y-83570-F0	SPEEDOMETER ASSY	1	
2	29R-83540-00	TACHOMETER ASSY	1	
3	29R-85750-00	FUEL METER ASSY	1	
4	31A-83740-00	DIGITAL CLOCK ASSY	1	
5	2HL-8353G-00	CASE, upper	1	
6	31A-8353H-00	CASE, inner	1	
7	31A-83559-00	COVER, meter	1	
8	90167-04021	SCREW, tapping	2	
9	90159-04043	SCREW, with washer	2	
10	92902-03600	WASHER, plate	3	
11	92990-03100	WASHER, spring	4	
12	95380-03600	NUT	4	
13	90159-03044	SCREW, with washer	3	
14	90164-04006	SCREW, tapping	7	
15	90164-03010	SCREW, tapping	3	
16	31A-83509-00	SOCKET CORD ASSY	1	
17	4G1-84744-00	BULB (12V-3.4W)	11	
18	31A-8353L-00	REFLECTOR	3	
19	31A-8357X-00	PANEL ASSY	1	
20	29L-83578-00	KNOB, trip meter	1	
21	31A-83592-00	DAMPER	2	
22	31A-83593-00	DAMPER	2	
23	90201-060A3	WASHER, plate	2	
24	90176-06055	NUT, crown	2	
25	16M-83550-00	SPEEDOMETER CABLE ASSY	1	

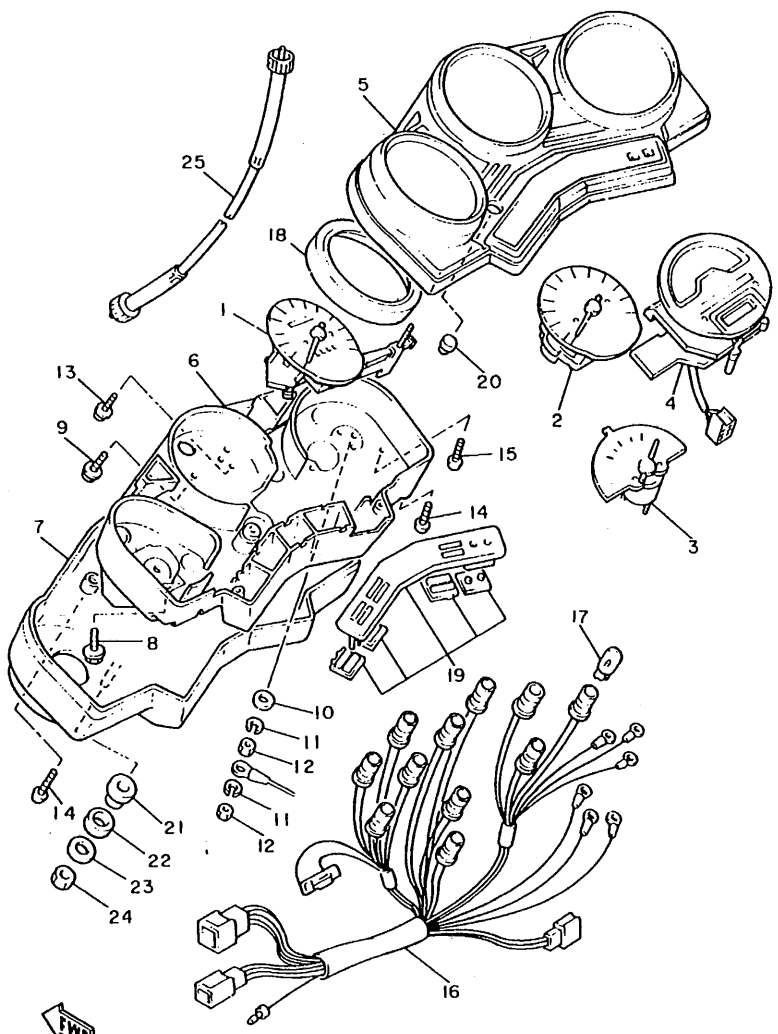

31E171-3420

FIG. 43 HEADLIGHT

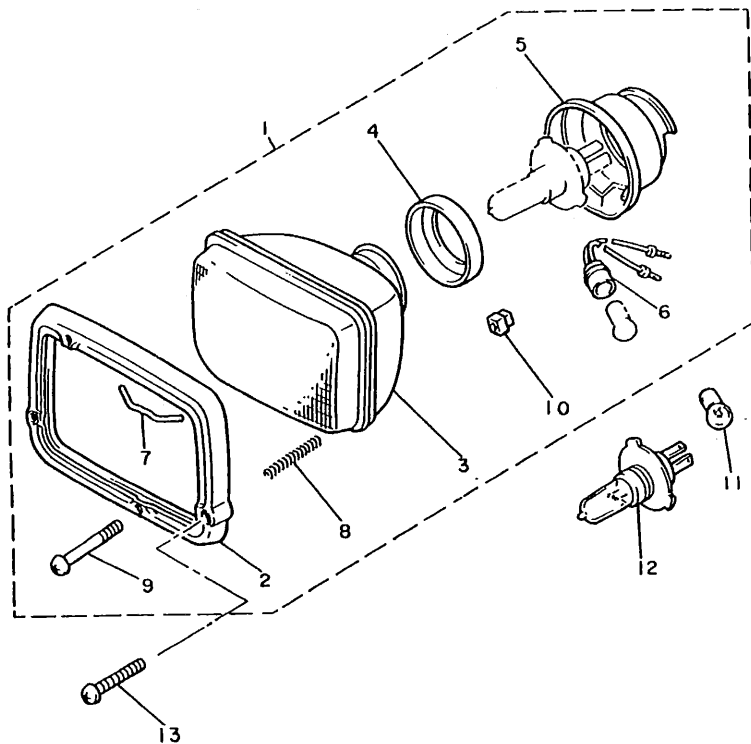

REF. NO.	PART NO.	DESCRIPTION	Q'TY	REMARKS
1	31A-84303-G0	HEADLIGHT UNIT ASSY	1	
2	31A-84315-00	.RIM, headlight	1	
3	11U-84321-G0	.LENS ASSY	1	
4	2F9-84375-00	.SETTING PLATE, bulb	1	
5	2F9-84397-01	.COVER, socket	1	
6	34L-84346-00	.SOCKET, pilot light	1	
7	5G2-84324-A0	.SPRING, reflector	1	
8	341-84332-60	.SPRING, screw	2	
9	98501-04050	.SCREW, pan head	2	
10	198-84334-60	.NUT, adjusting	2	
11	*	BULB (12V-4W)	1	LM
12	*	BULB (12V-60/55W)	1	LM HALOGEN
13	92780-06530	SCREW, flat head	2	



31A300-3430

F3

FIG. 44 TAILLIGHT

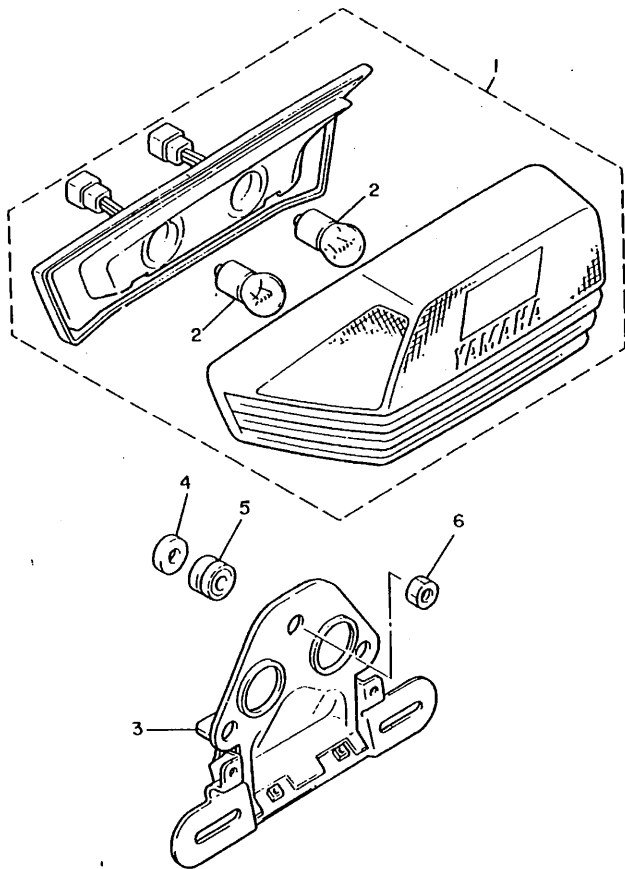

REF. NO.	PART NO.	DESCRIPTION	Q'TY	REMARKS
1	31A-84710-E1	TAILLIGHT UNIT ASSY	1	
2	137-84714-61	.BULB (12V-23/8W)	2	
3	31A-84751-E0	BRACKET, license	1	
4	4G0-84725-00	WASHER, special	3	
5	4G0-84754-00	WASHER, special	3	
6	95303-06600	NUT	3	



41Y310-4440

FIG. 45 HANDLE SWITCH • LEVER

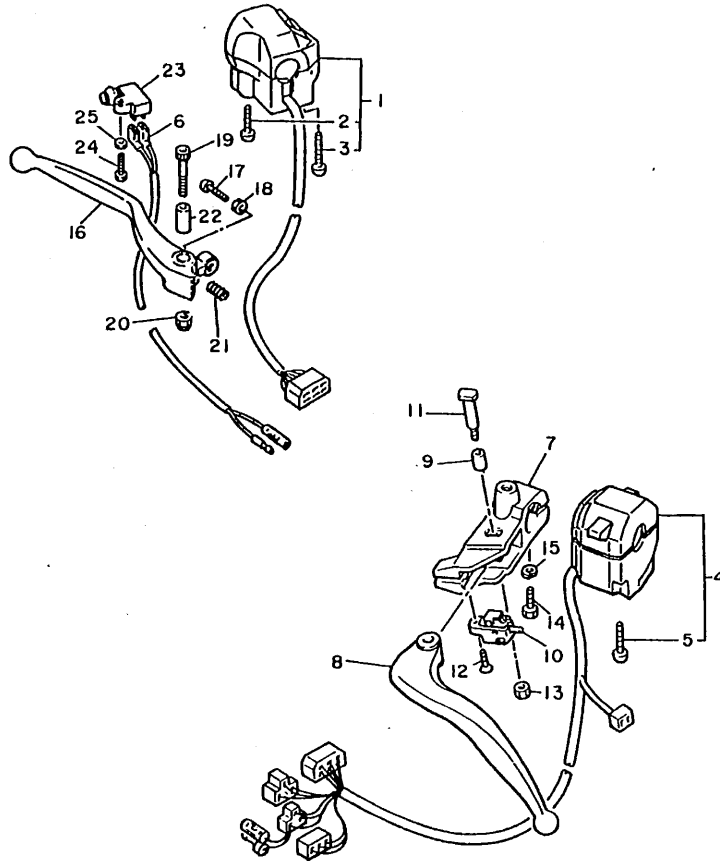

REF. NO.	PART NO.	DESCRIPTION	Q'TY	REMARKS
1	31A-83963-01	SWITCH, handle 3 (RIGHT)	1	
2	98506-05040	.SCREW, pan head	1	
3	98506-05045	.SCREW, pan head	1	
4	3NG-83972-00	SWITCH, handle 4	1	
5	98506-05035	.SCREW, pan head	2	
6	49A-82531-00	WIRE, lead	1	
7	41Y-82911-00	HOLDER, lever 1	1	
8	31A-83912-00	LEVER 1	1	
9	31A-83913-00	COLLAR, lever 1	1	
10	31A-82917-00	SWITCH	1	
11	31A-83945-00	BOLT, lever	1	
12	98702-03008	SCREW, flat head	1	
13	95616-06100	NUT, u	1	
14	97001-06025	BOLT	1	
15	92906-06100	WASHER, spring	1	
16	36Y-83922-00	LEVER 2	1	
17	90149-06131	SCREW	1	
18	90170-06010	NUT	1	
19	90110-06074	BOLT, hexagon socket head	1	
20	95616-06100	NUT, u	1	
21	90501-10312	SPRING, compression	1	
22	36Y-83913-01	COLLAR, lever 1	1	
23	J45-82503-01	SWITCH, alarm	1	
24	98506-04018	SCREW, pan head	1	
25	92906-04600	WASHER, plate	1	



3NG351-0450

FIG. 46 ELECTRICAL 1

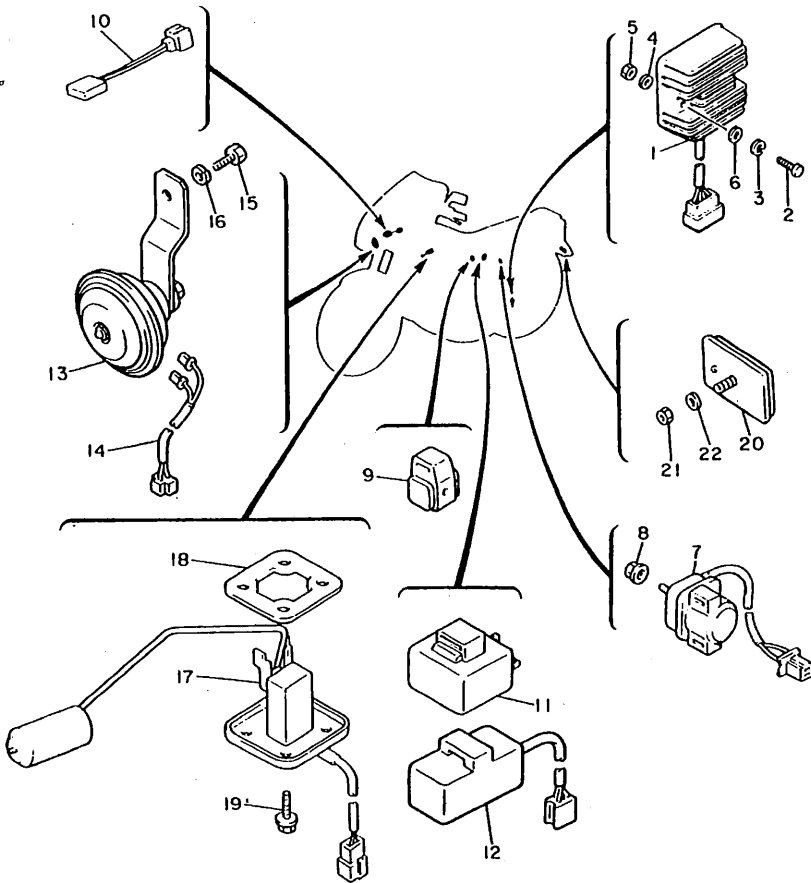

REF. NO.	PART NO.	DESCRIPTION	Q'TY	REMARKS
1	12R-81960-A1	RECTIFIER & REGULATOR ASSY	1	
2	97001-06035	BOLT	2	
3	92990-06100	WASHER, spring	2	
4	92990-06600	WASHER, plate	2	
5	95601-06100	NUT, u	2	
6	90201-06067	WASHER, plate	2	
7	3AY-81940-00	STARTER RELAY ASSY	1	
8	95701-06500	NUT, flange	2	
9	12R-81950-01	RELAY ASSY	1	
10	4H7-81980-M0	RECTIFIER 2	1	
11	4K0-83350-20	FLASHER RELAY ASSY	1	
12	1A0-83395-03	FLASHER CANCELLING UNIT	1	
13	1UA-83371-00	HORN	1	
14	2HL-83373-00	LEAD, horn	1	
15	97016-08016	BOLT	2	
16	92906-08100	WASHER, spring	2	
17	31A-85752-00	SENDER UNIT ASSY, fuel meter	1	
18	5G3-85753-00	GASKET, sender unit	1	
19	90119-05071	BOLT, with washer	4	
20	3G1-85130-01	REAR REFLECTOR ASSY	1	
21	95601-05100	NUT, u	1	
22	92990-05200	WASHER, plain	1	



3NG300-9460

FIG. 47 ELECTRICAL 2

REF. NO.	PART NO.	DESCRIPTION	Q'TY	REMARKS
1	447-82110-78	BATTERY ASSY (FB14L-A2)	1	YAMAHA
2	90445-08336	HOSE	1	
3	26H-82131-00	BAND, battery	1	
4	12R-82115-00	WIRE, plus lead	1	
5	31A-82119-00	.COVER, lead wire	1	
6	5G2-82116-00	WIRE, minus lead	1	
7	5G2-82103-00	TERMINAL 1	2	
8	90153-06032	SCREW, hexagon	2	
9	4H7-82310-61	IGNITION COIL ASSY	1	
10	4H7-82320-61	IGNITION COIL ASSY	1	
11	97001-06080	BOLT	2	
12	92990-06100	WASHER, spring	2	
13	95303-06600	NUT	2	
14	1J7-82370-00	PLUG CAP ASSY	2	
15	256-82370-00	PLUG CAP ASSY	2	
16	58L-82305-10	IGNITOR UNIT ASSY	1	
17	92502-06014	SCREW, pan head	2	
18	92990-06100	WASHER, spring	2	
19	92990-06600	WASHER, plate	2	
20	4G0-21736-00	NUT, plate	2	
21	2H7-82540-00	NEUTRAL SWITCH ASSY	1	
22	90430-10171	GASKET	1	
23	4H7-85720-01	OIL LEVEL GAUGE ASSY	1	
24	95023-06016	BOLT	2	
25	1E9-82530-02	STOP SWITCH ASSY	1	
26	41Y-82501-81	MAIN SWITCH STEERING LOCK	1	
27	90109-06614	BOLT	2	
28	58L-82590-10	WIRE HARNESS ASSY	1	

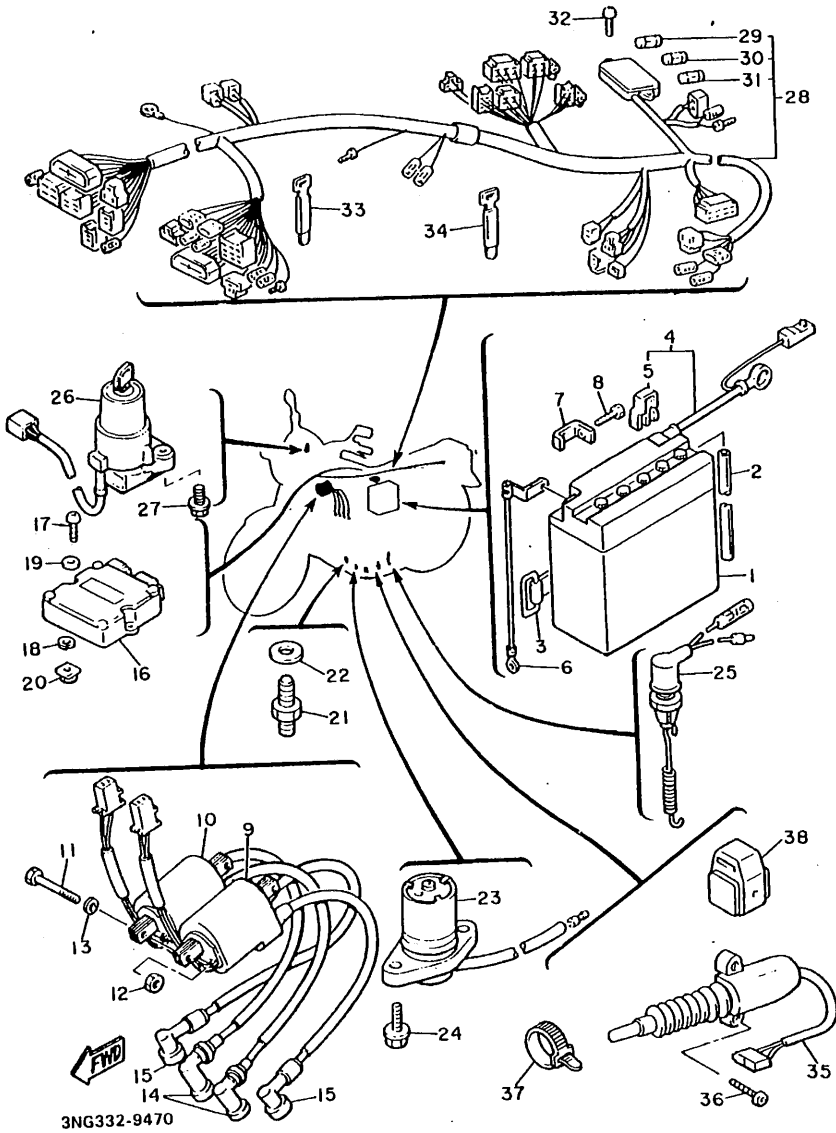
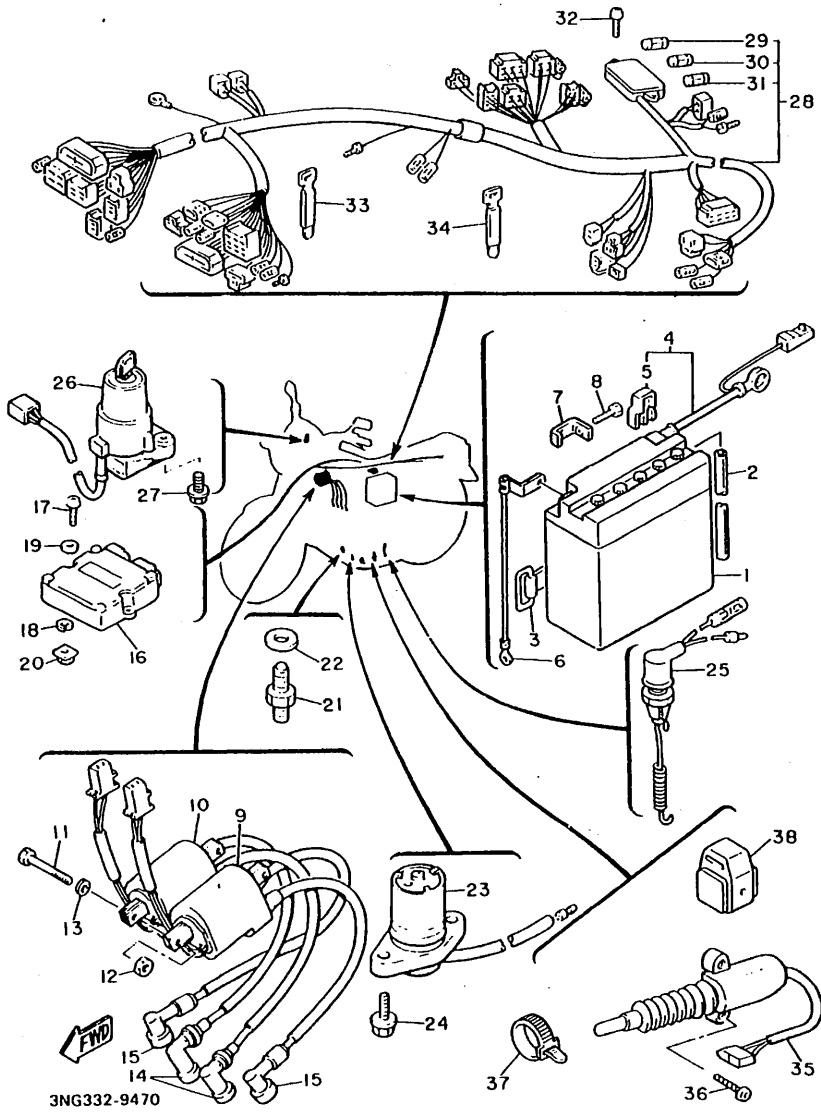

FIG. 47 ELECTRICAL 2

REF. NO.	PART NO.	DESCRIPTION	Q'TY	REMARKS
29	1A0-82151-00	.FUSE (12V-10A)	2	
30	1A0-82161-00	.FUSE (20A)	1	
31	2H7-82151-00	.FUSE (12V-30A)	1	
32	97702-50012	SCREW, tapping	2	
33	341-26397-01	BAND	3	
34	3TB-83936-00	BAND, switch cord	2	
35	5G8-82566-00	SWITCH, side stand	1	
36	98706-05016	SCREW, flat head	2	
37	341-26397-01	BAND	1	
38	4U8-81950-02	RELAY ASSY	1	FOR SIDE STAND



FOR ENGLAND

The following pages provides a listing of only the parts that meet the specifications peculiar to your market. For those parts not appearing in these pages, refer to the "GENERAL SPEC" section.

FIG. 48 ALTERNATE (ELECTRICAL)

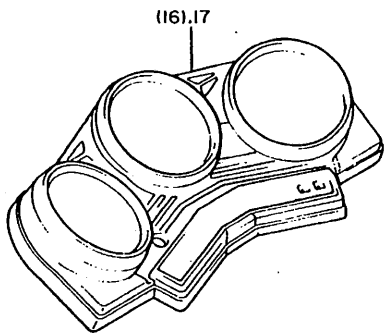
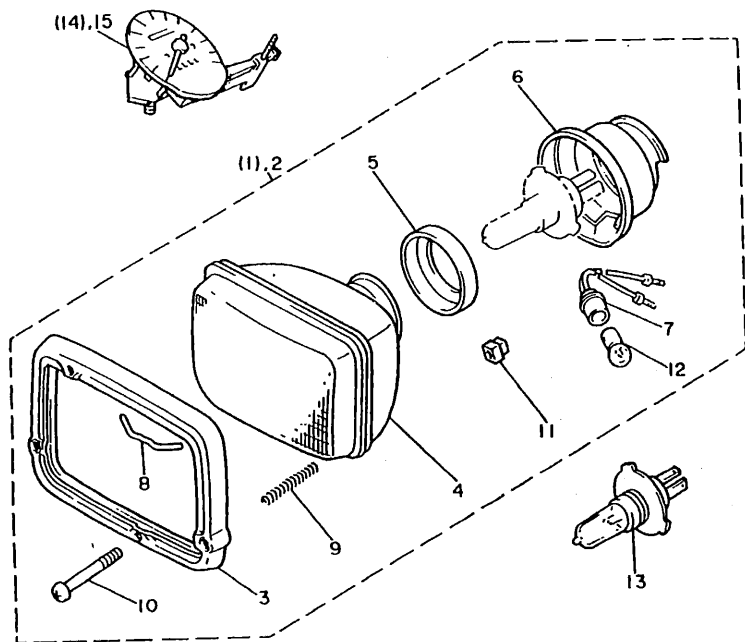

REF. NO.	PART NO.	DESCRIPTION	Q'TY	REMARKS
1	31A-84303-G0	HEADLIGHT UNIT ASSY	*	
2	31A-84303-E0	HEADLIGHT UNIT ASSY	1	
3	31A-84315-00	.RIM, headlight	1	
4	11U-84321-E0	.LENS ASSY	1	
5	2F9-84375-00	.SETTING PLATE, bulb	1	
6	2F9-84397-01	.COVER, socket	1	
7	34L-84346-00	.SOCKET, pilot light	1	
8	5G2-84324-A0	.SPRING, reflector	1	
9	341-84332-60	.SPRING, screw	2	
10	98501-04050	.SCREW, pan head	2	
11	198-84334-60	.NUT, adjusting	2	
12	123-83516-21	.BULB (12V-3.4W)	1	
13	*	BULB (12V-60/55W)	1	LM HALOGEN
14	41Y-83570-F0	SPEEDOMETER ASSY	*	
15	41Y-83570-G0	SPEEDOMETER ASSY	1	
16	2HL-8353G-00	CASE, upper	*	
17	31A-8353G-00	CASE, upper	1	



4BB300-2480

FOR FINLAND

The following pages provides a listing of only the parts that meet the specifications peculiar to your market. For those parts not appearing in these pages, refer to the "GENERAL SPEC" section.

FIG. 49 ALTERNATE (CHASSIS)

REF. NO.	PART NO.	DESCRIPTION	Q'TY	REMARKS
1	31A-21621-00	FLAP	1	
2	31A-21622-00	BAND, flap	1	
3	98516-06020	SCREW, pan head	2	
4	92906-06100	WASHER, spring	2	
5	90201-06057	WASHER, plate	2	

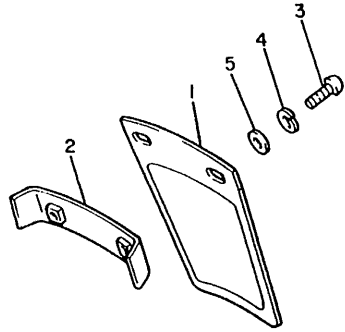

2HL300-7510



INDEX

(GENERAL SPEC.)

K1

NUMERICAL INDEX

PART NO.	GRID NO.	PART NO.	GRID NO.	PART NO.	GRID NO.
36Y-W0041-00	E - 5	58L-11636-00	B - 4	4H7-12241-00	B - 7
31A-W0042-50	E - 8	58L-11638-00	B - 4	4H7-12251-00	B - 7
26H-W0045-11	D-14	31A-11650-00	B - 4	4H7-12252-00	B - 7
1FK-W0046-01	E - 3	12R-11654-00	B - 4	5G2-13300-00	B - 8
31A-W0047-00	D-14	31A-11656-00	B - 4	4H7-13327-00	B - 8
	E - 3	31A-11656-10	B - 4	4H7-13328-00	B - 8
1J3-W0048-00	D-14	31A-11656-20	B - 4	4H7-13337-00	B-10
	E - 3	31A-11656-30	B - 4	1L9-13340-01	B-10
31A-W0057-00	D-14	31A-12111-00	B - 5	4H7-13354-00	B - 8
	E - 3	4H7-12113-00	B - 5	5G2-13355-00	B - 8
31A-W1751-01	C-10	4H7-12114-00	B - 5	4BB-13414-00	B-10
31A-W1752-00	C-10	4H7-12116-00	B - 5	31A-13417-00	B-10
2H9-W1812-00	C-13	2F3-12117-00	B - 5	1L9-13441-11	B-10
31A-W2472-00	D-12	1J7-12118-00	B - 5	4H7-13447-00	B-10
53U-Y2835-70-4Y	E-10	1J7-12119-01	B - 5	4H7-13454-00	C - 2
53U-Y2835-90-5Y	E-10	31A-12121-00	B - 5	3VD-13455-00	B-10
31A-11101-01	B - 2	31A-12153-00-E0	B - 6		D - 6
2GH-1111G-00	B - 2	4H7-12153-01-J0	B - 6	5N1-13461-01	B - 9
4H7-11133-10	B - 2	1J7-12169-A1	B - 5	31A-13464-01	B - 9
4H7-11161-00	B - 2	1J7-12169-E1	B - 5	31A-13465-01	B - 9
434-11161-00	B - 2	1J7-12169-F1	B - 5	31A-13470-01	B - 9
5G2-11166-00	C - 3	1J7-12169-G1	B - 5	2H9-13493-00	B - 9
58L-11181-00	B - 2	1J7-12169-H1	B - 5	4BB-13556-00	B-11
42N-11191-00	B - 2	1J7-12169-J1	B - 5	16G-13569-00	B-11
31A-11193-00	B - 2	1J7-12169-K1	B - 5	31A-13586-00	B-11
214-11198-01	B-10	1J7-12169-L1	B - 5	31A-13596-00	B-11
	D - 6	1J7-12169-M1	B - 5	58L-1410A-00	B-12
58L-11310-00	B - 3	1J7-12169-N1	B - 5	31A-14103-00	B-13
4BB-11351-00	B - 3	1J7-12169-R1	B - 6	12R-14105-00	B-12
4H7-11363-00	B -15	1J7-12169-T1	B - 6	25G-14107-23	B-12
31A-11411-00	B - 4	1J7-12169-U1	B - 6	4U8-14122-00	B-13
4H7-11416-01	B - 4	1J7-12169-V1	B - 6	49A-14139-00	B-13
4H7-11416-11	B - 4	1J7-12169-W1	B - 6	4G0-14142-40	B-12
4H7-11416-21	B - 4	1J7-12169-01	B - 5	2H0-14146-00	B-12
4H7-11416-31	B - 4	1J7-12169-11	B - 5	214-14147-00	B-12
4H7-11416-41	B - 4	1J7-12169-21	B - 5	36Y-14147-00	B-13
5G2-11418-00	B - 4	1J7-12169-31	B - 5	822-14147-00	B-13
5G2-11418-10	B - 4	1J7-12169-41	B - 5	137-14153-00	B-12
5G2-11418-20	B - 4	1J7-12169-51	B - 6	537-14186-00	B-12
5G2-11418-30	B - 4	1J7-12169-61	B - 5	2L1-14191-00	B-12
5G2-11418-40	B - 4	1J7-12169-71	B - 5	3GM-14197-00	B-13
4H7-11456-00	C - 5	1J7-12169-81	B - 5	620-1423A-20	B-12
4H7-11474-01	C - 5	1J7-12169-91	B - 5	3G2-14231-32	B-13
58L-11610-00	B - 4	31A-12171-00	B - 7	17A-14251-00	B-13
58L-11610-20	B - 4	4G0-12176-01	B - 7	31A-14401-00	B-11
58L-11610-40	B - 4	31A-12181-00	B - 7	31A-14412-00	B-11
58L-11631-00-E0	B - 4	12R-12210-00	B - 7	31A-14419-00	B-11
58L-11633-00	B - 4	3YX-12213-00	B - 7	31A-14435-00	B-11

NUMERICAL INDEX

PART NO.	GRID NO.	PART NO.	GRID NO.	PART NO.	GRID NO.
32F-14437-00	B -11	31A-15381-00	B -15	1J7-16385-00	C - 6
31A-14451-00	B -11	31A-15383-00	B -15	4H7-16398-00	C - 6
31A-14452-00	B -11	5G2-15409-00	C - 3	4BB-17121-00	C - 8
31A-14453-00	B -11	4H7-15412-01	C - 4	4H7-17141-00	C - 8
51Y-14462-00	B -11	4H7-15415-00	C - 3	4H7-17151-00	C - 8
812-14594-00	B -12	22N-15416-01	C - 3	4H7-17211-01	C - 8
58L-14611-00	B -14	5G2-15417-00	C - 4	4BB-17221-00	C - 8
31A-14612-00	B -14	4H7-15421-02	C - 4	4BB-17231-00	C - 8
4BR-14613-00	B -14	22N-15426-01	C - 3	4H7-17241-00	C - 8
58L-14615-00	B -14	31A-15431-01	C - 3	16G-17251-00	C - 8
58L-14621-00	B -14	4H7-15441-01	C - 2	4H7-17401-00	C - 8
58L-14631-00	B -14	22N-15449-00	C - 3	4H7-17402-01	C - 8
1AE-14638-00	B -14	4H7-15449-00	C - 4	278-17424-01	C - 8
3JJ-14653-00	B -14	4BB-15451-00	C - 3	4H7-17524-00	C-10
58L-14641-00	B -14	4BB-15455-00	C - 3	31A-17526-00	C-10
32F-14711-00	B -14	4BB-15456-00	C - 3	31A-17527-00	C-10
32F-14721-00	B -14	4BB-15457-00	C - 3	3H5-17529-00	C-10
36Y-14747-00	B -14	4BB-15461-00	C - 4	3JB-17531-10	C-10
3XW-14755-00	B -14	4BB-15467-00	C - 3	3JB-17531-20	C-10
4K0-14791-00	B -14	4H7-15486-00	C - 4	3JB-17531-30	C-10
36Y-1490J-00	B -12	4H7-15511-01	E -14	4H7-17531-00-15	C-10
31A-1490K-00	B -13	4H7-15512-00	C - 5	4H7-17531-00-40	C-10
58L-1490L-00	B -13	1J7-15517-00	C - 5	1J7-17537-Y0-15	D - 5
31A-1490M-00	B -13	4H7-15519-00	C - 5	1J7-17537-Y0-30	D - 5
4BB-14900-00	B -12	4H7-15521-00	C - 5	1J7-17537-Y0-40	D - 5
58L-14901-10	B -12	4H7-15522-00	C - 5	1J7-17537-Y0-50	D - 5
58L-14902-10	B -12	4H7-15524-00	C - 5	1J7-17537-Y0-60	D - 5
58L-14903-10	B -12	2H7-15531-00	C - 5	4H7-17537-00-20	C-10
58L-14904-10	B -12		C-12	4H7-17537-00-30	C-10
3G1-14933-00	B -12	31A-15580-00	C - 5	4H7-17537-00-40	C-10
4BB-14940-00	B -12	341-15583-05	C - 5	4H7-17555-00	C-10
16H-14941-90	B -12	117-15644-00	C-12	4L6-17582-00	C - 8
3XW-14984-00	B -12	58L-16150-00	C - 6	31A-17583-00	C - 8
3H5-14985-00	B -12	2K7-16154-00	C - 7	2H7-17590-00	D - 6
1J7-14988-00	B -13	4H7-16154-00	C - 6	4K0-18101-01	C-13
31A-14988-00	B -13	4H7-16155-01	C - 5	41Y-18111-00	C-13
31A-15100-02	B -15	4H7-16181-00	C - 7	2H9-18112-00	C-13
4H7-15138-00	B -15	31A-16321-00	C - 6	132-18113-01	C-13
22N-15144-00	C - 3	4H7-16321-00	C - 6	4K0-18115-00	C-13
4H7-15163-01	B -15	168-16324-00	C - 6	4K0-18120-01	C-13
16G-15164-00	C - 2	31A-16325-00	C - 6	4H7-18140-00	C-13
4H7-15167-10	B -15	4H7-16340-00	C - 6	2H9-18154-00	C-13
4H7-15189-00	C - 2	58L-16351-00	C - 6	16G-18185-00	C-12
4H7-15346-00	C - 3	3LD-1637A-00	C - 6	4K0-18197-00	C-13
4H7-15347-00	C - 3	58L-16371-01	C - 6	4H7-18511-01	C-12
2H7-15361-00	C - 4	4H7-16382-01	C - 6	4H7-18512-01	C-12
2H7-15363-00	C - 4	5G2-16383-00	C - 6	4H7-18513-01	C-12
4H7-15365-00	C - 2	1J7-16384-00	C - 6	4H7-18531-00	C-12

NUMERICAL INDEX

PART NO.	GRID NO.	PART NO.	GRID NO.
16G-18540-00	C-12	1FW-23110-00	D-9
42N-21110-10-33	C-14	3KM-23111-00	D-8
31A-21147-00	C-14		D-9
31A-21165-00	D-12	1W1-23114-L0	D-8
31A-21170-00	D-3		D-9
31A-21240-00	D-3	4H7-23119-00	D-8
31A-21245-00	D-3		D-9
31A-21275-00	D-12	31A-23125-31	D-8
26H-21308-00	D-12		D-9
31A-21315-00-33	C-14	41Y-23126-00	D-8
31A-21510-00-GE	C-15	18G-23128-00	D-9
31A-21510-00-AU	C-15	122-23129-00	D-8
1A8-21518-00	C-15		D-9
31A-21523-00	C-15	31A-2313A-30	D-9
31A-21524-00	C-15	41Y-23136-00	D-8
3NG-21596-00	C-15	1FW-23141-00	D-8
31A-21611-00	C-15		D-9
31A-21629-00	C-15	1W1-23142-L0	D-8
31A-21638-00	D-2		D-9
4G0-21639-00	C-15	41Y-23144-00	D-8
31A-21645-00	C-15		D-9
31A-21651-00-P1	C-15	41Y-23145-00	D-8
31A-21651-00-VA	C-15	41Y-23146-00	D-8
31A-21653-00	C-15		D-9
4BB-21660-20	D-2	31A-23149-31	D-8
4BB-21660-10	D-2		D-9
31A-21711-01-6Y	D-3	3R4-23153-00	D-8
31A-21711-01-7Y	D-3	509-23158-L0	D-8
31A-21721-01-6Y	D-3		D-9
31A-21721-01-7Y	D-3	26H-23168-00	D-8
4BB-2173E-10	D-3		D-9
4BB-2173E-20	D-3	1FW-23170-00	D-8
4BB-2173F-10	D-3		D-9
4BB-2173F-20	D-3	5A8-23173-00	D-8
4G0-21736-00	F-7		D-9
4H7-21746-00	D-3	278-23181-50	D-8
4H7-2175R-00	D-3		D-9
31A-22110-02-35	D-4	31A-23181-30	D-9
1J7-22141-00	D-4	1FW-23340-00	D-9
4H7-22141-00	D-4	4U8-23356-10	D-8
1J7-22143-00	D-4		D-9
4H7-22189-00	D-4	1J7-23415-00	D-7
5G2-2219X-00	D-4	26H-23418-01	D-7
3NG-22210-00	D-4	29R-23435-01-98	D-7
3NG-22210-10	D-4	31A-23469-02	E-4
1FW-23102-01	D-8	4K0-2411M-00	D-10
1FW-23103-01	D-8	31A-24110-00-W3	D-10
1FW-23110-00	D-8	31A-24110-00-W5	D-10

PART NO.	GRID NO.	PART NO.	GRID NO.
4H7-24181-00	D-10	4H7-24181-00	D-10
31A-24182-00	D-10	4K0-24183-00	D-10
4K0-24186-00	D-10	4K0-24186-00	D-10
31A-24188-00	D-10	31A-24188-00	D-10
58L-2419A-00	B-11	58L-2419A-00	B-11
4BB-24240-00	D-10	4BB-24240-00	D-10
4BB-24240-10	D-10	4BB-24240-10	D-10
31A-24500-01	D-10	31A-24500-01	D-10
2G2-24512-00	D-10	2G2-24512-00	D-10
16G-24518-00	D-10	16G-24518-00	D-10
2G2-24522-00	D-10	2G2-24522-00	D-10
16G-24523-00	D-10	16G-24523-00	D-10
2G2-24534-00	D-10	2G2-24534-00	D-10
41Y-24602-01	D-10	41Y-24602-01	D-10
41Y-24705-01	D-12	41Y-24705-01	D-12
509-24724-00	D-12	509-24724-00	D-12
31A-24728-00	D-12	31A-24728-00	D-12
31A-24731-00	D-12	31A-24731-00	D-12
31A-24738-00	D-12	31A-24738-00	D-12
31A-2476A-00	D-12	31A-2476A-00	D-12
31A-2476E-00	D-12	31A-2476E-00	D-12
31A-24760-00	D-12	31A-24760-00	D-12
1A1-25115-00	D-15	1A1-25115-00	D-15
146-25115-00	D-13	146-25115-00	D-13
341-25149-00	D-13	341-25149-00	D-13
31E-25168-00-WG	D-13	31E-25168-00-WG	D-13
31A-25181-00	D-13	31A-25181-00	D-13
31A-25190-00	D-13	31A-25190-00	D-13
31A-25327-00	D-15	31A-25327-00	D-15
31E-25338-20-WG	D-15	31E-25338-20-WG	D-15
4G0-25364-00	D-15	4G0-25364-00	D-15
31A-25366-00	D-15	31A-25366-00	D-15
31A-25371-00	D-15	31A-25371-00	D-15
56W-25377-00	D-15	56W-25377-00	D-15
31A-25381-00	D-15	31A-25381-00	D-15
29L-25398-00	D-13	29L-25398-00	D-13
29L-25398-10	D-13	29L-25398-10	D-13
31A-26372-00	D-15	31A-26372-00	D-15
5H0-26393-00	D-15	5H0-26393-00	D-15
341-26397-01	F-8	341-26397-01	F-8
31A-27111-00-R4	E-6	31A-27111-00-R4	E-6
1A0-27114-00	B-14	1A0-27114-00	B-14
27H-27114-A0	D-12	27H-27114-A0	D-12
41Y-27211-00	E-8	41Y-27211-00	E-8
31A-27212-00	E-8	31A-27212-00	E-8
31A-27222-00	E-8	31A-27222-00	E-8

NUMERICAL INDEX

PART NO.	GRID NO.	PART NO.	GRID NO.
2KT-25831-00	D-14	2KT-25831-00	D-14
31A-25831-51	E-3	31A-25831-51	E-3
41Y-25836-00	E-3	41Y-25836-00	E-3
341-25846-00	D-13	341-25846-00	D-13
31A-25850-50	E-8	31A-25850-50	E-8
36Y-25850-01	E-5	36Y-25850-01	E-5
2KF-25852-50	E-8	2KF-25852-50	E-8
36Y-25852-01	E-5	36Y-25852-01	E-5
36Y-25854-00	E-5	36Y-25854-00	E-5
360-25854-00	E-8	360-25854-00	E-8
2GU-25855-00	E-8	2GU-25855-00	E-8
4L0-25862-00	E-5	4L0-25862-00	E-5
38Y-25867-00	E-5	38Y-25867-00	E-5
31A-25872-51	E-8	31A-25872-51	E-8
4K0-25872-00	E-5	4K0-25872-00	E-5
31A-25873-02	E-5	31A-25873-02	E-5
31A-25873-12	E-5	31A-25873-12	E-5
1FW-25885-00	E-5	1FW-25885-00	E-5
31A-25894-01	E-8	31A-25894-01	E-8
31A-25895-00	E-8	31A-25895-00	E-8
26H-25919-00	E-3	26H-25919-00	E-3
29L-25919-00	D-14	29L-25919-00	D-14
1KT-25924-00	D-14	1KT-25924-00	D-14
26H-25925-00	D-14	26H-25925-00	D-14
29R-26121-01	E-4	29R-26121-01	E-4
29R-26122-02	E-4	29R-26122-02	E-4
36Y-26133-00	E-4	36Y-26133-00	E-4
31A-26213-00	E-4	31A-26213-00	E-4
31A-26216-00	E-4	31A-26216-00	E-4
58L-2622F-00	E-4	58L-2622F-00	E-4
31A-26240-00	E-4	31A-26240-00	E-4
31A-26241-00	E-4	31A-26241-00	E-4
58L-26246-00	E-4	58L-26246-00	E-4
36Y-26290-G0	E-4	36Y-26290-G0	E-4
36Y-26290-T0	E-4	36Y-26290-T0	E-4
31A-26311-00	E-4	31A-26311-00	E-4
31A-26335-01	E-4	31A-26335-01	E-4
1J7-46117-Y0-50	E-4	1J7-46117-Y0-50	E-4
5H0-26393-00	E-4	5H0-26393-00	E-4
22U-46118-00-12	D-6	22U-46118-00-12	D-6
22U-46118-00-14	D-6	22U-46118-00-14	D-6
22U-46118-00-16	D-6	22U-46118-00-16	D-6
22U-46118-00-18	D-6	22U-46118-00-18	D-6
22U-46118-00-20	D-6	22U-46118-00-20	D-6
2H7-46122-00	D-5	2H7-46122-00	D-5
4H7-46123-00	D-5	4H7-46123-00	D-5
4H7-46125-00	D-5	4H7-46125-00	D-5
31E-27311-00-R4	E-6	31E-27311-00-R4	E-6
5G2-27351-00	E-6	5G2-27351-00	E-6
41Y-27410-00	E-6	41Y-27410-00	E-6
31A-27412-01	E-6	31A-27412-01	E-6
22N-27413-00	E-6	22N-27413-00	E-6
41Y-27420-00	E-6	41Y-27420-00	E-6
31A-27422-01	E-6	31A-27422-01	E-6
29L-27430-00	E-6	29L-27430-00	E-6
22N-27433-00	E-6	22N-27433-00	E-6
29L-27440-00	E-6	29L-27440-00	E-6
31A-27442-00	E-6	31A-27442-00	E-6
31A-27443-00	E-7	31A-27443-00	E-7
1FX-28100-00	D-3	1FX-28100-00	D-3
4BB-28301-10	E-11	4BB-28301-10	E-11
4BB-28301-20	E-11	4BB-28301-20	E-11
42N-2831U-00	E-10	42N-2831U-00	E-10
42N-28317-00	E-10	42N-28317-00	E-10
42N-28335-00	E-10	42N-28335-00	E-10
42N-28336-00	E-10	42N-28336-00	E-10
42N-2834K-00	E-11	42N-2834K-00	E-11
31A-28345-00	E-10	31A-28345-00	E-10
3JJ-2835Y-00	E-10	3JJ-2835Y-00	E-10
3JJ-2835Y-10	E-10	3JJ-2835Y-10	E-10
42N-28358-00	E-10	42N-28358-00	E-10
42N-28357-00	E-10	42N-28357-00	E-10
42N-28358-00	E-11	42N-28358-00	E-11
53U-2836K-01	E-11	53U-2836K-01	E-11
42N-28376-00	E-10	42N-28376-00	E-10
53U-28376-00	E-11	53U-28376-00	E-11
2HL-28381-00	E-10	2HL-28381-00	E-10
42N-28385-00-GE	E-11	42N-28385-00-GE	E-11
42N-28385-00-AU	E-11	42N-28385-00-AU	E-11
4BB-28390-20	E-10	4BB-28390-20	E-10
4BB-28390-10	E-10	4BB-28390-10	E-10
31A-46101-00	D-5	31A-46101-00	D-5
1J7-46117-Y0-25	D-5	1J7-46117-Y0-25	D-5
1J7-46117-Y0-30	D-5	1J7-46117-Y0-30	D-5
1J7-46117-Y0-40	D-5	1J7-46117-Y0-40	D-5
1J7-46117-Y0-45	D-5	1J7-46117-Y0-45	D-5
58L-82305-10	F-7	58L-82305-10	F-7
4H7-82310-61	F-7	4H7-82310-61	F-7
4H7-82320-61	F-7	4H7-82320-61	F-7
1J7-82370-00	F-7	1J7-82370-00	F-7
256-82370-00	F-7	256-82370-00	F-7
41Y-82501-81	F-7	41Y-82501-81	F-7
J45-82503-01	F-5	J45-82503-01	F-5
1E9-82530-02	F-7	1E9-82530-02	F-7
49A-82531-00	F-5	49A-82531-00	F-5

NUMERICAL INDEX

PART NO.	GRID NO.	PART NO.	GRID NO.	PART NO.	GRID NO.
2H7-82540-00	F - 7	2F9-84397-01	F - 3	90119-05071	F - 6
6G8-82566-00	F - 8	31A-84710-E1	F - 4	90119-06029	B - 11
68L-82590-10	F - 7		F - 9	90119-06044	D - 2
41Y-82911-00	F - 5	137-84714-61	F - 4	90119-06108	C - 15
31A-82917-00	F - 5	4G0-84726-00	F - 4		E-10
31A-83301-40	E - 15	4G1-84744-00	F - 2	90119-06118	D - 3
31A-83303-40	E - 15	31A-84751-E0	F - 4	90123-08046	E - 4
306-83311-40	E - 15	4G0-84754-00	F - 4	90149-06008	D - 10
11M-83312-00	E - 15	3G1-85130-01	F - 6	90149-06131	F - 5
6G2-83312-00	E - 15	4H7-85720-01	F - 7	90149-06154	D - 12
6G2-83313-00	E - 15	29R-85750-00	F - 2	90149-08152	B - 15
4G0-83317-00	E - 15	31A-85752-00	F - 6	90150-05023	E - 10
4G0-83318-00	E - 15	6G3-85763-00	F - 6	90151-06014	C - 2
4V8-83318-00	E - 15	90101-06576	B - 14	90153-06029	B - 2
4L0-83321-00	E - 15	90101-12480	E - 4	90153-06032	F - 7
4K0-83350-20	F - 6	90102-10056	D - 15	90154-05001	E - 11
1UA-83371-00	F - 6	90105-06153	B - 2	90154-06014	E - 11
2HL-83373-00	F - 6	90105-06154	B - 8	90159-03044	F - 2
1A0-83395-03	F - 6	90105-07087	B - 7	90159-04043	F - 2
31A-83609-00	F - 2	90105-08155	D - 6	90159-06056	E - 8
2HL-8363G-00	F - 2	90105-08278	C - 14	90159-06092	C - 6
31A-8363H-00	F - 2	90105-10038	C - 14	90159-06107	E - 13
31A-8353L-00	F - 2	90105-10152	E - 12	90164-03010	F - 2
29R-83640-00	F - 2	90105-10169	C - 14	90164-04006	F - 2
16M-83560-00	F - 2	90105-10308	D - 14	90167-04021	F - 2
31A-83559-00	F - 2		E - 3	90170-06010	F - 5
31A-8357X-00	F - 2	90105-12208	C - 14	90170-06228	C - 13
41Y-83570-F0	F - 2	90106-10030	D - 4	90170-10219	D - 15
29L-83578-00	F - 2	90109-064F0	B - 2	90170-20327	C - 6
31A-83592-00	F - 2	90109-06468	E - 8	90176-06055	F - 2
31A-83593-00	F - 2	90109-06614	F - 7	90176-10009	D - 4
31A-83740-00	F - 2	90109-08579	D - 10	90176-10013	D - 4
31A-83912-00	F - 5	90109-08718	D - 14	90176-10049	B - 2
31A-83913-00	F - 5		E - 3	90179-06403	E - 4
36Y-83913-01	F - 5	90109-10570	B - 7	90179-06499	B - 3
36Y-83922-00	F - 5	90109-10590	E - 6		B - 14
3TB-83936-00	F - 8	90109-10606	E - 6	90179-08148	E - 4
31A-83945-00	F - 5	90109-10748	D - 6	90179-08246	C - 14
31A-83963-01	F - 5	90110-06035	B - 8	90179-08327	B - 4
3NG-83972-00	F - 5	90110-06074	F - 5	90179-10247	C - 14
31A-84303-G0	F - 3	90110-06145	C - 2	90179-12421	C - 14
31A-84315-00	F - 3	90116-06466	B - 2	90179-14217	D - 15
11U-84321-G0	F - 3	90116-08360	D - 5	90179-14317	C - 10
6G2-84324-A0	F - 3	90116-10249	D - 5	90179-18360	C - 10
341-84332-60	F - 3	90116-10328	B - 15	90179-22412	D - 7
198-84334-60	F - 3	90116-10329	B - 15	90179-25033	D - 7
34L-84346-00	F - 3	90116-10330	B - 15	90185-10037	E - 6
2F9-84375-00	F - 3	90116-10361	D - 5	90185-10060	E - 6

NUMERICAL INDEX

PART NO.	GRID NO.	PART NO.	GRID NO.	PART NO.	GRID NO.
90185-14070	D - 5	90387-06500	D - 2	90501-10312	F - 5
90201-060A3	F - 2	90387-067K8	E - 10	90501-12413	B - 9
90201-06067	F - 6	90387-07598	B - 9	90501-16491	D - 6
90201-06074	E - 11	90387-093H1	D - 3	90501-20422	B - 10
90201-08083	E - 8	90387-124F4	C - 13	90501-224A8	C - 6
90201-084G3	B - 3	90387-125A2	C - 2	90501-70762	C - 10
90201-094G1	B - 15	90387-15550	D - 13	90506-07136	D - 4
90201-10118	E - 5	90387-16547	B - 16	90506-08227	C - 13
	E - 9	90387-170J6	D - 15	90506-20249	E - 8
90201-10128	B - 2	90387-172A5	D - 6	90506-40348	E - 6
90201-10131	B - 2	90387-17543	D - 4	90507-29033	E - 6
90201-10142	D - 4	90387-202A7	C - 5	90508-16459	C - 6
90201-10437	D - 4	90387-252A8	C - 7	90508-29530	C - 13
90201-105A2	E - 6	90401-10096	E - 5	90508-32535	C - 13
90201-12M34	C - 6		E - 9	90560-08237	E - 10
90201-12166	C - 13	90401-20089	B - 9	90560-15116	D - 13
90201-124E4	C - 13	90430-06014	B - 2	90560-17204	D - 15
90201-12790	B - 3	90430-14131	B - 3	90601-11525	E - 8
90201-144J5	D - 15	90445-08336	F - 7	91311-06020	C - 2
90201-14632	D - 5	90445-09500	D - 10	91311-06025	B - 7
90201-14633	C - 10	90445-11182	B - 11		C - 3
90201-150H2	C - 6	90445-11501	D - 10		C - 4
90201-20276	C - 8	90460-52264	B - 11	91311-06030	B - 10
90201-21608	B - 10	90460-58015	B - 11	91311-06040	B - 10
90201-231A2	D - 6	90461-08031	E - 9		C - 3
90201-243A2	C - 8	90462-10066	B - 9		C - 4
90201-25526	B - 9	90462-10067	B - 9	91311-06070	C - 3
90202-06010	D - 10	90462-13032	B - 12	91311-06080	E - 4
90202-26142	D - 7	90464-12027	C - 15	91311-10020	E - 7
90209-06096	C - 4	90465-08156	E - 13	91311-10025	B - 14
90209-06173	B - 9	90465-08277	E - 13		E - 7
90209-06174	B - 9	90465-12160	E - 13	91316-06016	B - 9
90209-11262	B - 2	90467-08021	D - 10	91316-06020	B - 11
90209-22191	C - 8	90467-09006	B - 11	91316-06025	B - 8
90209-22252	C - 8	90467-10008	D - 10		B - 9
90209-25196	C - 8	90467-10039	B - 11		E - 5
90215-06040	C - 5	90467-14015	C - 3	91316-08014	C - 5
90215-20231	C - 6	90468-03063	D - 11	91316-08030	E - 13
90215-22238	D - 4	90468-08104	C - 3	91401-20015	D - 15
90215-23194	C - 10	90480-01401	D - 3		E - 8
90240-08013	E - 8	90480-12053	D - 3	91401-30030	D - 15
90269-05039	E - 11	90480-15235	B - 9	92501-06014	C - 3
90331-12028	C - 5	90480-16233	D - 3		C - 4
90340-12062	B - 3	90480-16284	B - 9	92502-06014	F - 7
90340-14042	D - 6	90480-18276	E - 10	92516-06030	E - 4
90387-060J5	E - 10	90480-22362	E - 10	92780-06530	F - 3
90387-060A7	B - 9	90480-23193	B - 10	92901-04100	E - 12
	D - 3	90501-04503	C - 5	92901-04600	E - 12

NUMERICAL INDEX

PART NO.	GRID NO.	PART NO.	GRID NO.	PART NO.	GRID NO.
92901-05100	B -13	92990-08100	D - 8	93306-20465	C - 8
92901-06600	B - 3		D - 9	93306-20541	C - 5
	B -11	92990-08600	C -15	93306-20709	C -10
	C -15	92990-10100	D - 4	93306-30203	D -13
92901-08600	B - 7	92990-12200	E - 4	93306-30306	D -15
	B -14	92990-14200	D -13	93306-30311	C - 8
	C - 6	93101-30084	D - 5	93306-30528	C - 8
	D - 8	93101-32144	B - 4	93306-30533	D - 5
	D - 9	93101-35097	C -10	93306-90501	C -12
92901-08700	D - 6	93101-38098	D - 5	93306-91101	C - 8
92902-03600	F - 2	93102-12106	C -13	93310-365H3	C - 7
92902-08100	C -15	93102-12224	C - 6	93311-36042	C - 9
	D - 3	93102-22014	D -13	93311-43729	D - 5
92906-04100	E - 8	93102-25017	D - 4	93315-11206	C - 6
92906-04600	E - 8	93102-25044	D -15	93315-23208	B - 8
	F - 5	93102-25218	C - 5	93316-01403	D - 5
92906-05600	D - 2	93102-70167	D - 6	93317-11020	C - 6
92906-06100	C -14	93105-45017	D -13	93317-41510	D - 5
	E - 4	93108-23007	D - 6	93332-00008	D - 7
	E - 5	93210-07438	C - 2	93332-00010	D - 4
	E - 9	93210-07540	C - 2	93332-00023	D - 7
	E -11	93210-08006	B - 7	93340-21505	C - 6
	E -15	93210-09350	C -13	93410-22039	D - 6
92906-06600	F - 5	93210-09443	B - 3	93410-23056	D - 6
	B -14	93210-10197	B - 9	93410-32052	C - 5
92906-08100	E - 4	93210-11124	B -15	93410-55057	C - 8
	D - 4	93210-14359	C -10	93440-11029	C -12
	E - 8	93210-15620	E - 8	93440-12052	B - 2
	F - 6	93210-16629	B -10	93440-12066	C -13
92906-10100	D - 6	93210-18319	B - 8	93440-25084	C - 8
92906-10200	E - 2	93210-18322	B -15	93440-28062	C - 8
92990-03100	F - 2	93210-20573	C - 2	93440-47081	C -10
92990-05200	F - 6	93210-27778	C - 4	93440-72049	C - 9
92990-05600	E -15	93210-37532	B -11	93440-80082	C - 9
92990-06100	B -11	93210-48530	D -15	93450-17044	B - 4
	C -15	93210-57428	D -15	93604-08071	E -13
	D - 2	93210-60426	D - 5	93604-10011	C -12
	D -12	93210-62439	C - 2	93604-16092	C -12
	E - 8	93210-71360	C -10	93608-43157	C -12
	E -12	93210-71462	B - 3	93608-50158	C -13
	E -14	93210-87723	B - 9	93615-12088	C - 5
	F - 6		B -10	93900-00031	D -13
	F - 7	93211-44348	D - 6		D -15
92990-06600	D -12	93302-20306	D -15	94580-25062	B - 8
	E -12	93306-00401	C - 5	94580-58120	B - 7
92990-06600	F - 6	93306-00508	C -10	94681-01021	B - 7
	F - 7	93306-20310	D -15	94701-00219	B - 2
92990-08100	B -12	93306-20439	C - 8	95023-06016	F - 7

NUMERICAL INDEX

PART NO.	GRID NO.	PART NO.	GRID NO.	PART NO.	GRID NO.
95026-08025	B -14	95816-08020	D -12	98506-05040	F - 5
95303-05600	E -15	95816-08070	C -14	98506-05045	F - 6
95303-06600	E -14	95821-08025	C -15	98511-04012	E -12
	F - 4	95826-06010	E -10	98511-04016	E -15
	F - 7	95826-06020	B - 9	98580-05010	B -12
95303-06700	C -13	95826-08045	D - 7		B -13
95303-06800	C -15	95826-08045	F - 5	98580-06008	D -10
95303-08700	E - 8	97001-06025	F - 6	98701-05035	C -12
95303-10700	B - 7	97001-06035	F - 7	98702-03008	F - 5
95311-06600	B - 3	97001-06080	E -11	98706-04012	E - 5
95311-08700	B - 9	97006-06035	C -13	98706-05016	F - 8
95333-08600	B - 3	97011-06020	C -15	98901-06008	B -10
	D - 6	97011-08016	B -14	98980-06020	C - 3
	D - 8	97011-08025	D - 3	99001-09600	C - 7
97016-06016	E -11	97016-06016	E -11	99006-10600	C -13
97016-08016	F - 6	97016-08016	F - 6	99009-17500	B - 9
97016-08025	E - 8	97016-08025	E - 8	99009-20400	C - 8
97021-06014	C - 5	97021-06014	C - 5	99080-07600	C - 6
97026-06010	E -15	97026-06010	E -15	99224-00045	D -10
97026-06012	C -14	97026-06012	C -14	99234-00020	E -10
	E - 9		E - 9	99234-00055	E -11
97026-08035	D - 4		D - 4	99236-00020	E -10
	E - 8		E - 8	99238-00055	E -11
97313-06016	C - 5		C - 5	99240-00045	D -10
	C -12		C -12	99510-08016	B - 2
	C -15		C -15		B -10
	D - 2		D - 2	99510-12016	B -15
97701-40535	E -15		E -15	99530-10014	C - 3
97702-50012	F - 8		F - 8		C - 4
97801-06014	B -13		B -13	99530-14016	B - 3
98006-06020	E -10		E -10		
98302-05006	B -12		B -12		
98501-04006	B -12		B -12		
98501-04050	F - 3		F - 3		
98501-05010	D -15		D -15		
98501-05016	B -12		B -12		
98501-06010	B -10		B -10		
	C - 3		C - 3		
98501-06020	B -11		B -11		
	D -12		D -12		
98501-06025	B -11		B -11		
98502-06016	E -12		E -12		
98503-03008	D -10		D -10		
98506-04012	E - 8		E - 8		
98506-04018	F - 5		F - 5		
98506-05010	D - 2		D - 2		
	E - 6		E - 6		
98506-05035	F - 5		F - 5		

INDEX

(INDIVIDUAL SPEC.)

L1

NUMERICAL INDEX

PART NO.	GRID NO.
31A-21621-00	F -13
31A-21622-00	F -13
123-83516-21	F -11
2HL-8353G-00	F -11
31A-8353G-00	F -11
41Y-83570-G0	F -11
31A-84303-E0	F -11
31A-84316-00	F -11
11U-84321-E0	F -11
5G2-84324-A0	F -11
341-84332-60	F -11
198-84334-60	F -11
34L-84346-00	F -11
2F9-84375-00	F -11
2F9-84397-01	F -11
90201-06057	F -13
92906-06100	F -13
98501-04050	F -11
98516-06020	F -13

PART NO.	GRID NO.
----------	----------

PART NO.	GRID NO.
----------	----------

PART NO.	GRID NO.
----------	----------

NUMERICAL INDEX

PART NO.	GRID NO.
----------	----------

PART NO.	GRID NO.
----------	----------



